

JVC



COMPACT COMPONENT SYSTEM

نظام اجهزة صوتية مركبة

CA-MXDVA5



Video CD



PlayBack Control

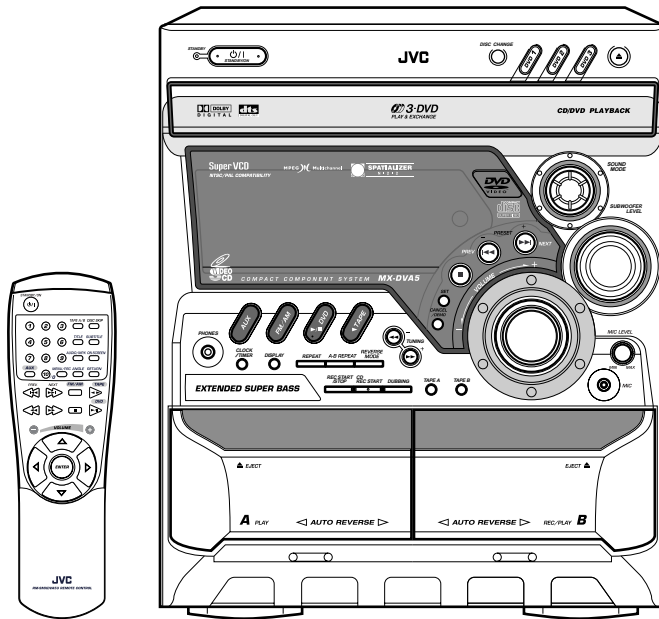

MPEG Multichannel



INSTRUCTIONS

كتيب تعليمات التشغيل

For Customer Use:

Enter below the Model No. and Serial No. which are located either on the rear, bottom or side of the cabinet. Retain this information for future reference.

Model No. _____

Serial No. _____

LVT0748-001A
[UG]

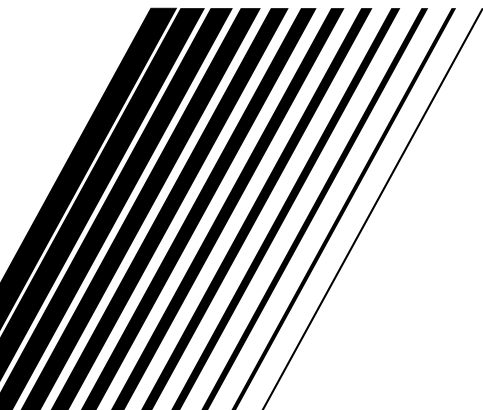

Warnings, Cautions and Others

تحذيرات، تنبيهات وأشياء أخرى

Caution — ⏻ switch!

Disconnect the mains plug to shut the power off completely. The ⏻ switch in any position does not disconnect the mains line. The power can be remote controlled.

تحذير - ⏻ الطاقة

انزع قابس الطاقة الكهربائية من أجل فصل الطاقة الكهربائية عن الجهاز كلياً. لا يفصل مفتاح الطاقة الكهربائية عندما يكون بأي وضع ⏻ الطاقة الكهربائية عن الجهاز. يمكن التحكم عن بعد بالطاقة الكهربائية.

CAUTION

To reduce the risk of electrical shocks, fire, etc.:

1. Do not remove screws, covers or cabinet.
2. Do not expose this appliance to rain or moisture.

CAUTION

- Do not block the ventilation openings or holes. (If the ventilation openings or holes are blocked by a newspaper or cloth, etc., the heat may not be able to get out.)
- Do not place any naked flame sources, such as lighted candles, on the apparatus.
- When discarding batteries, environmental problems must be considered and local rules or laws governing the disposal of these batteries must be followed strictly.
- Do not use this apparatus in a bathroom or places with water. Also do not place any containers filled with water or liquids (such as cosmetics or medicines, flower vases, potted plants, cups, etc.) on top of this apparatus.

تحذير

لتجنب خطر الحريق، الصدمات الكهربائية، الخ.:

١. لا تقم بفتح البواقي، الاغطية أو الخزائن.
٢. لا تقم بتعريض هذا الجهاز للمطر أو للرطوبة.

تحذير

- لا تعيق فتحات أو ثقوب التهوية. (إذا تمت إعاقة فتحات أو ثقوب التهوية بواسطة جريدة أو القماش، ... الخ، لا يمكن إخراج الحرارة.)
- لا تضع أية مصادر واضحة للاحتراق، مثل الشموع المضيئة، على الجهاز.
- عند رمي البطاريات، يجب الأخذ بنظر الاعتبار المشاكل البيئية والتقيد الكامل بالقواعد المحلية أو قوانين الحكومة المتعلقة بكيفية التخلص من هذه البطاريات.
- لا تستعمل هذا الجهاز في الحمام أو الأماكن التي تحتوي على الماء. كذلك أيضاً لا تضع أية حاويات مملوءة بالماء أو السوائل (مثل مستحضرات التجميل، الأدوية، مزهريات الزهور، أو أواني فخارية للنباتات، الكواب، ... الخ) على قمة الجهاز.

Caution: Proper Ventilation

To avoid risk of electric shock and fire, and to prevent damage, locate the apparatus as follows:

- 1 Front: No obstructions and open spacing.
- 2 Sides/ Top/ Back: No obstructions should be placed in the areas shown by the dimensions below.
- 3 Bottom: Place on the level surface. Maintain an adequate air path for ventilation by placing on a stand with a height of 10 cm or more.

تحذير: التهوية الصحيحة

لتجنب حصول صدمات كهربائية واطار الحريق ومنع حصول تلف وضرر للجهاز، ركّب الجهاز كما يلي:
١ الجهة الامامية: يجب ان لا يكون هنالك عوائق ويجب ان تكون المنطقة مفتوحة امام الجهاز.
٢ الجهات الجانبية / العلوية / الخلفية: يجب عدم وضع عوائق في المناطق المبينة بالابعاد في الاسفل.
٣ القاعدة: يجب وضع الجهاز على سطح منبسط. اترك مسافة كافية من اجل التهوية بواسطة وضع الجهاز على حامل بارتفاع ١٠ سم او اكثر.

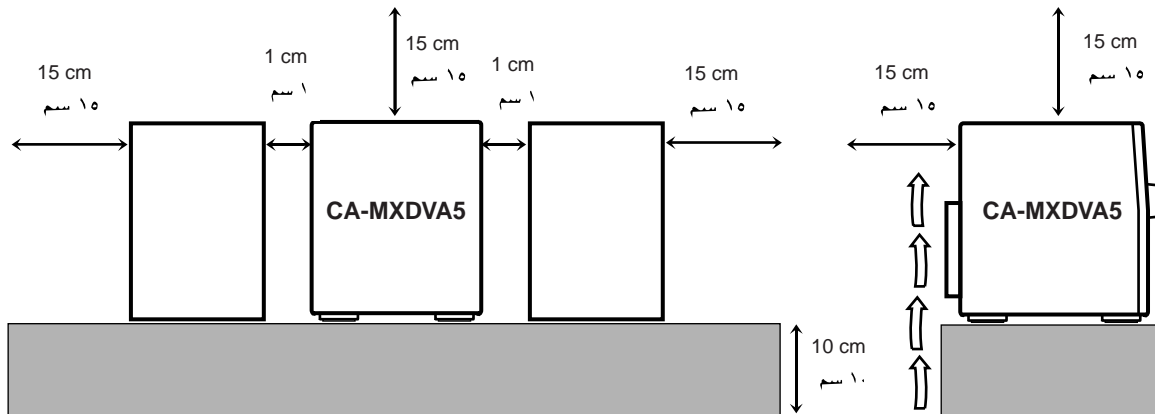

IMPORTANT FOR LASER PRODUCTS / مهم للمنتجات الليزرية

REPRODUCTION OF LABELS / إنتاج اللاصقات

- ① CLASSIFICATION LABEL, PLACED ON REAR ENCLOSURE ② WARNING LABEL, PLACED INSIDE THE UNIT

① لاصق التصنيف، موضوعة على المرفق الخلفي

② لاصقة التحذير، موضوعة بداخل الجهاز

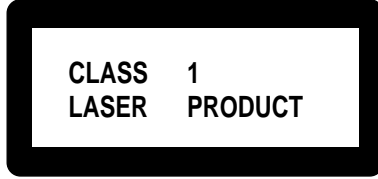

DANGER: Invisible laser radiation when open and interlock failed or defeated. AVOID DIRECT EXPOSURE TO BEAM. (e)	VARNING: Osynlig laserstrålning när denna del är öppnad och spärren är urkopplad. Betrakta ej strålen. (s)	ADVÅRSEL: Usynlig laserstrålning ved åbning, når sikkerhedsafbrydere er ude af funktion. Undgå udsættelse for stråling (d)	VARO: Avattaessa ja suojalukitus ohitettaessa olet alltiina näkyvättömälle lasersäteilylle. Älä katso säteeseen. (f)
-------------------------------------------------------------------------------------------------------------------------	-------------------------------------------------------------------------------------------------------------------	-----------------------------------------------------------------------------------------------------------------------------------	-----------------------------------------------------------------------------------------------------------------------------

1. CLASS 1 LASER PRODUCT
2. **DANGER:** Invisible laser radiation when open and interlock failed or defeated. Avoid direct exposure to beam.
3. **CAUTION:** Do not open the top cover. There are no user serviceable parts inside the Unit; leave all servicing to qualified service personnel.

١. صنف ١ منتج ليزري
٢. **خطر:** أشعة ليزرية غير مرئية عند الفتح والأغلاق الفاشل أو غير الصحيح. تجنب التعرض المباشر للأشعة.
٣. **تحذير:** لا تفتح الغطاء العلوي. ليس في داخل الجهاز أقسام بمستطاع المستخدم صيانتها؛ إعهد بكافة الأعمال الصيانة لفتي مختص.

Introduction

We would like to thank you for purchasing one of our JVC products. Before operating this unit, read this manual carefully and thoroughly to obtain the best possible performance from your unit, and retain this manual for future reference.

About This Manual

This manual is organized as follows:

- **The manual mainly explains operations using the buttons and controls on the unit. You can also use the buttons on the remote control if they have the same or similar names (or marks) as those on the unit. If operation using the remote control is different from that using the unit, it is then explained.**
- Basic and common information that is the same for many functions is grouped in one place, and is not repeated in each procedure. For instance, we do not repeat the information about turning on/off the unit, setting the volume, changing the sound effects, and others, which are explained in the section “Common Operations” on pages 10 to 12.
- The following marks are used in this manual:



Gives you warnings and cautions to prevent damage or risk of fire/electric shock. Also gives you information which is not good for obtaining the best possible performance from the unit.



Gives you information and hints you had better know.

Precautions

Installation

- Install in a place which is level, dry and neither too hot nor too cold — between 5°C (41°F) and 35°C (95°F).
- Install the unit in a location with adequate ventilation to prevent internal heat built-up in the unit.
- Leave sufficient distance between the unit and the TV.
- Keep the speakers away from the TV to avoid interference with TV.



DO NOT install the unit in a location near heat sources, or in a place subject to direct sunlight, excessive dust or vibration.

Power sources

- When unplugging from the wall outlet, always pull the plug, not the AC power cord.



DO NOT handle the AC power cord with wet hands.

Moisture condensation

Moisture may condense on the lens inside the unit in the following cases:

- After starting heating in the room
 - In a damp room
 - If the unit is brought directly from a cold to a warm place
- Should this occur, the unit may malfunction. In this case, leave the unit turned on for a few hours until the moisture evaporates, unplug the AC power cord, and then plug it in again.

Others

- Should any metallic object or liquid fall into the unit, unplug the unit and consult your dealer before operating any further.
- If you are not going to operate the unit for an extended period of time, unplug the AC power cord from the wall outlet.



DO NOT disassemble the unit since there are no user serviceable parts inside.

If anything goes wrong, unplug the AC power cord and consult your dealer.

Contents

Location of the Buttons and Controls	3	Special Effect Playback	25
Front Panel	3	Still Picture/Frame-by-frame Playback	25
Remote Control	5	Slow Motion Playback	25
Getting Started	6	Zoom	25
Unpacking	6	Locating Your Favorite Scenes	26
Putting the Batteries into the Remote Control	6	Marking the Scenes You Want — Bookmark	26
Connecting Antennas	6	Viewing tracks of a VCD	27
Connecting Speakers	7	Operating Setup Menu	28
Connecting Other Equipment	8	Setting the Setup Menu Language	28
Adjusting the Voltage Selector	9	Setting the Initial Disc Language	28
Cancelling the Display Demonstration	9	Setting the Initial Audio Language	29
Common Operations	10	Setting the Initial Subtitle Language	29
Turning On or Off the Power	10	Setting the Parental Level	30
Setting the Clock	10	Setting the Digital Audio Output	31
Selecting the Sources	10	Setting the DTS Signal Output	31
Adjusting the Volume	11	Setting the Dynamic Compression	32
Reinforcing the Bass Sound	11	Setting the Audio Output during 2X Speed Search ..	32
Selecting the Sound Modes	12	Setting the TV Aspect	33
Creating a Being-There Feeling	12	Setting the Angle Mark	34
Setting the AM Tuner Interval Spacing	12	Setting the Still Picture Quality	34
Listening to FM and AM Broadcasts	13	Setting the Screen Messages	35
Tuning in a Station	13	Setting the Brightness	35
Presetting Stations	13	Playing Back Tapes	36
Tuning in a Preset Station	13	Playing Back a Tape	36
DVD Introduction	14	Recording	37
Basic Disc Playback	15	Recording a Tape on Deck B	37
Loading Discs	15	Dubbing Tapes	38
Playing Back the Entire Discs		CD Synchronized Recording	38
— Continuous Play	15	Enjoying Karaoke Play	39
Basic Disc Operations	16	Singing Along (Karaoke) — Basic Procedure	39
Showing the On-Screen Display	16	Singing Along Using Multiplex Karaoke Discs	39
Searching for a Particular Point	18	• Request (Karaoke Program Play)	39
Prohibiting Disc Ejection — Tray Lock	18	• Vocal Fader	40
DVD Playback	19	• Guide Melody	40
Selecting the Subtitles	19	• Key Control	41
Selecting the Audio Language	19	Singing Along Using Multiplex Tapes — Multiplex	
Selecting the Multi-Angle Views	19	Sound (MPX)	41
Menu-Driven Playback	20	Singing Along Using the Conventional Stereo	
Menu Operations	20	Sources — Vocal Masking	41
Selecting Playback Modes	21	Using the Timers	42
Programming the Playing Order of the Chapters or		Using Daily Timer	42
Tracks — Program Play	21	Using Recording Timer	43
Playing at Random — Random Play	23	Using Sleep Timer	44
Repeating Playback	24	Timer Priority	44
• Repeat Play	24	Maintenance	45
• A-B Repeat	24	Glossary	46
Special Effect Playback	25	Troubleshooting	47
Still Picture/Frame-by-frame Playback	25	Specifications	48
Slow Motion Playback	25		
Zoom	25		
Locating Your Favorite Scenes	26		
Marking the Scenes You Want — Bookmark	26		
Viewing tracks of a VCD	27		
Operating Setup Menu	28		
Setting the Setup Menu Language	28		
Setting the Initial Disc Language	28		
Setting the Initial Audio Language	29		
Setting the Initial Subtitle Language	29		
Setting the Parental Level	30		
Setting the Digital Audio Output	31		
Setting the DTS Signal Output	31		
Setting the Dynamic Compression	32		
Setting the Audio Output during 2X Speed Search ..	32		
Setting the TV Aspect	33		
Setting the Angle Mark	34		
Setting the Still Picture Quality	34		
Setting the Screen Messages	35		
Setting the Brightness	35		
Playing Back Tapes	36		
Playing Back a Tape	36		
Recording	37		
Recording a Tape on Deck B	37		
Dubbing Tapes	38		
CD Synchronized Recording	38		
Enjoying Karaoke Play	39		
Singing Along (Karaoke) — Basic Procedure	39		
Singing Along Using Multiplex Karaoke Discs	39		
• Request (Karaoke Program Play)	39		
• Vocal Fader	40		
• Guide Melody	40		
• Key Control	41		
Singing Along Using Multiplex Tapes — Multiplex			
Sound (MPX)	41		
Singing Along Using the Conventional Stereo			
Sources — Vocal Masking	41		
Using the Timers	42		
Using Daily Timer	42		
Using Recording Timer	43		
Using Sleep Timer	44		
Timer Priority	44		
Maintenance	45		
Glossary	46		
Troubleshooting	47		
Specifications	48		

Location of the Buttons and Controls

Become familiar with the buttons and controls on your unit.

Front Panel

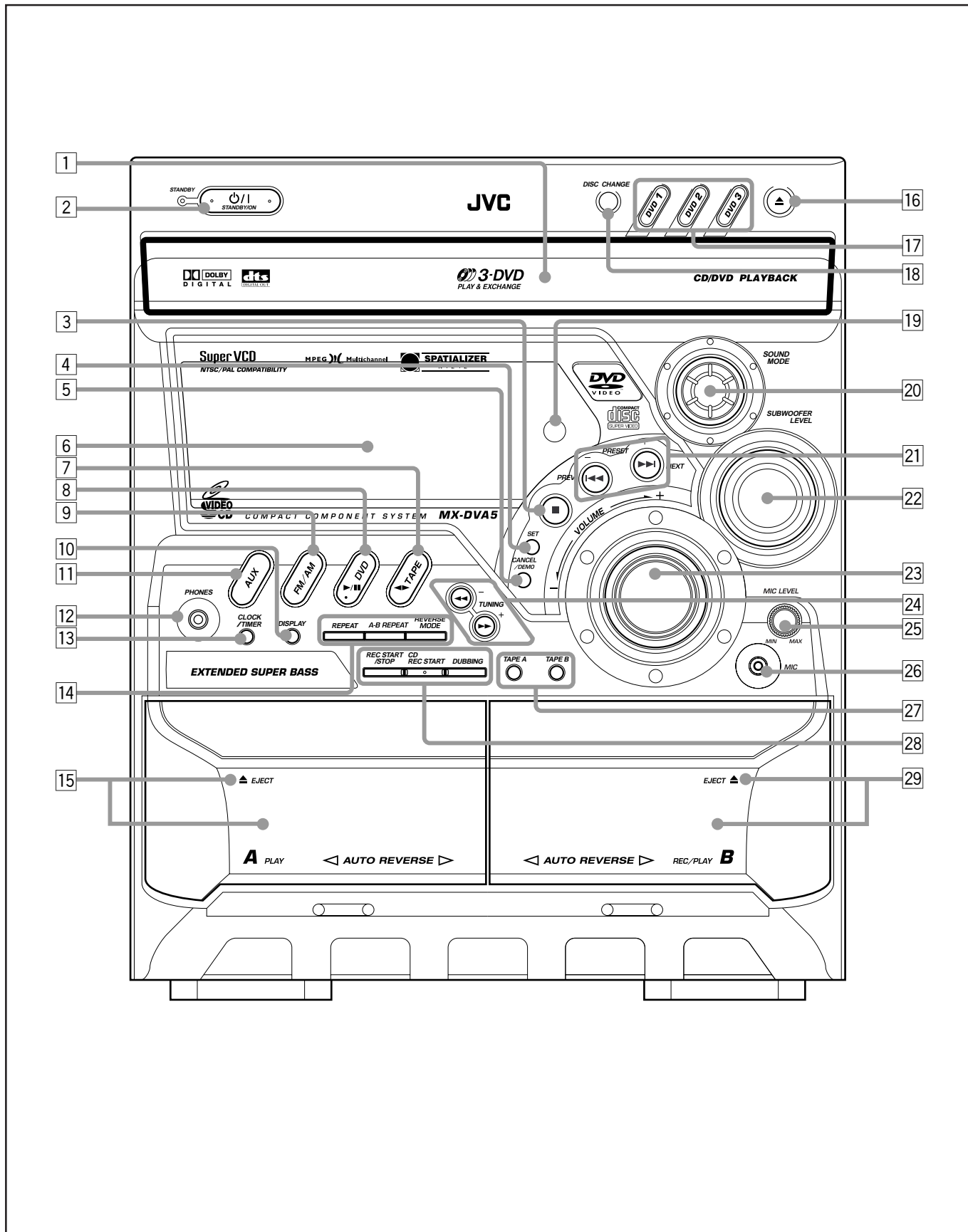

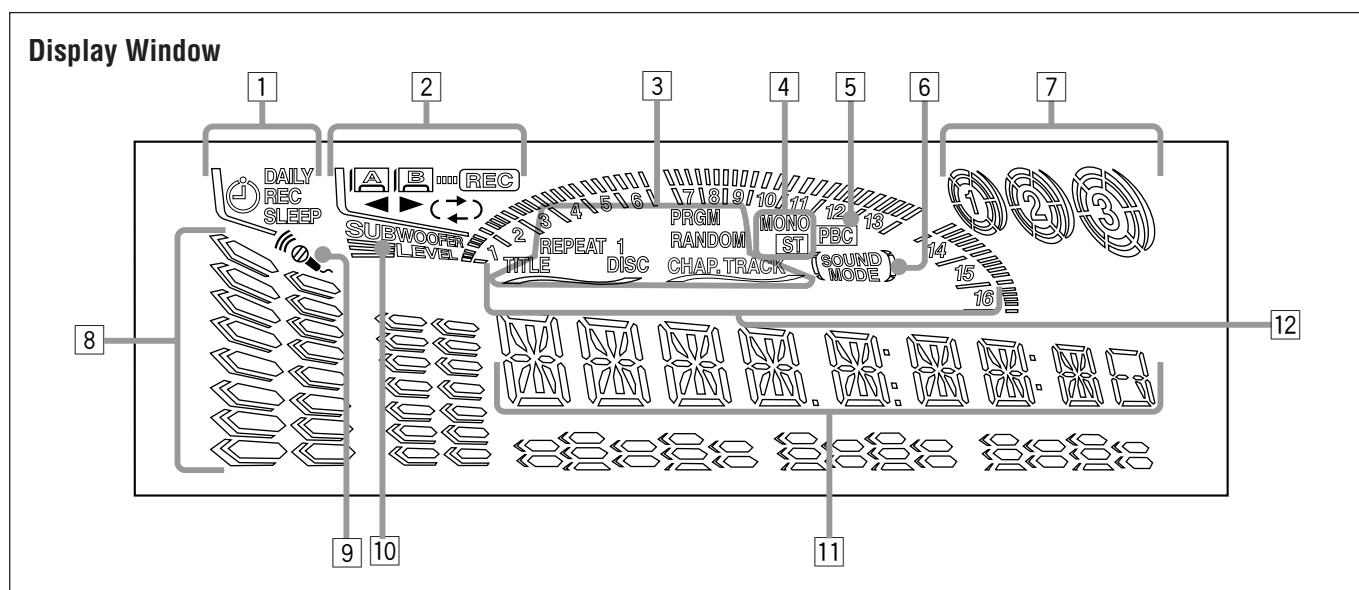

See pages in the parentheses for details.

Front Panel

- 1 Carrousel
- 2 **⏻**/STANDBY/ON button and STANDBY lamp (10, 12)
- 3 **■** (stop) button (15, 18, 21, 23, 36 – 38)
- 4 SET button (10, 13, 42 – 44)
- 5 CANCEL button (10, 42 – 44)
DEMO button (9)
- 6 Display window
- 7 TAPE **◀▶** button and lamp (10, 36 – 38)
 - Pressing this button also turns on the unit.
- 8 DVD **▶/||** (play/pause) button and lamp (10, 15, 16, 21, 23, 25, 26, 39)
 - Pressing this button also turns on the unit.
- 9 FM/AM button and lamp (10, 13)
 - Pressing this button also turns on the unit.
- 10 DISPLAY button (10)
- 11 AUX button and lamp (10)
 - Pressing this button also turns on the unit.
- 12 PHONES jack (11)
- 13 CLOCK/TIMER button (10, 42 – 44)
- 14 REPEAT button (24)
 - A-B REPEAT button (24)
 - REVERSE MODE button (36 – 38)
- 15 Deck A cassette holder (36, 38)
 - Pressing the **▲** EJECT portion opens the holder.
- 16 **▲** (Carrousel open/close) button (15, 16, 18)
 - Pressing this button also turns on the unit.
- 17 Disc number buttons and lamps (DVD1, DVD2, and DVD3) (15, 16, 21 – 23, 38)
 - Pressing one of these buttons also turns on the unit.
- 18 DISC CHANGE button (15, 16)
- 19 Remote sensor
- 20 SOUND MODE control (12)
- 21 PRESET **+ / -** buttons (13)
 - ◀◀ / ▶▶** (reverse search/forward search) buttons (10, 16, 42 – 44)
 - PREV. (previous) / NEXT button (20, 27)

- 22 SUBWOOFER LEVEL control (11)
- 23 VOLUME control (11, 39)
- 24 TUNING **+ / -** buttons (13)
 - ◀◀ / ▶▶** (fast rewind/fast forward) buttons (12, 18, 25, 36)
- 25 MIC LEVEL button (39)
- 26 MIC jack (39)
- 27 TAPE A button (15, 36)
TAPE B button (36)
- 28 REC START/STOP button (37, 39)
CD REC START button (38)
DUBBING button (30, 38)
- 29 Deck B cassette holder (36 – 38)
 - Pressing the EJECT **▲** portion opens the holder.

Display window

- 1 Timer indicators
 - DAILY (daily timer), REC (recording timer), SLEEP (sleep timer), and **⌚** (timer) indicators
- 2 Tape operation indicators
 - A/B (operating deck), REC (recording), **◀▶** (tape direction) and **↺↻** (reverse mode) indicators
- 3 Disc play mode indicators
 - REPEAT (1, 1 DISC), TITLE, PRGM (program), RANDOM, and CHAP.TRACK indicators
- 4 Tuner operation indicators
 - MONO and ST (stereo) indicators
- 5 PBC indicator
- 6 SOUND MODE indicator
- 7 Disc indicators
- 8 Volume level, Subwoofer level, and Sound Mode pattern indicators
- 9 Karaoke (**🎤**) and echo (**🔊**) indicators
- 10 SUBWOOFER LEVEL indicator
- 11 Main display
 - Shows the source name, frequency, etc.
- 12 Disc track number indicators

Remote Control

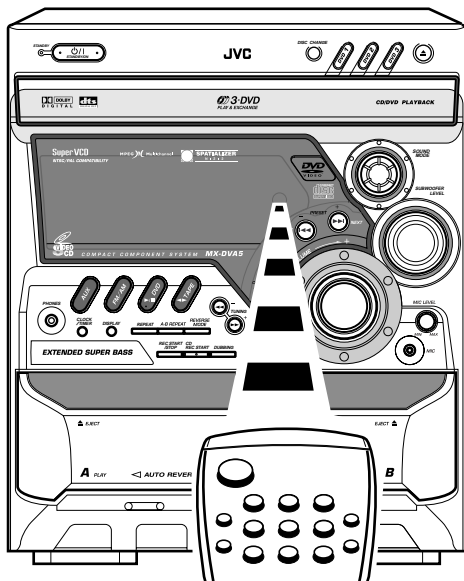
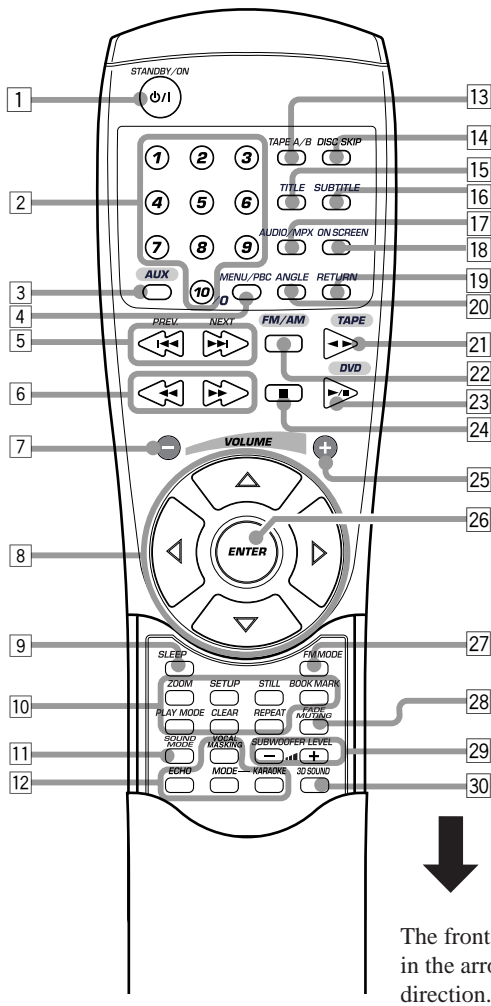

When using the remote control, point it at the remote sensor on the front panel.

Remote Control

- 1 STANDBY/ON button (10)
- 2 Number buttons (13, 16, 17, 20 - 22, 39)
- 3 AUX button (10)
 - Pressing this button also turns on the unit.
- 4 MENU/PBC button (20)
- 5 buttons (16)
 - PREV.(previous) / NEXT buttons (20)
- 6 buttons (13, 18, 25, 36)
- 7 VOLUME - button (11)
- 8 Cursor () buttons
- 9 SLEEP button (44)
- 10 Disc operation buttons
 - ZOOM button (25)
 - SETUP button (28 - 35)
 - STILL button (16, 25)
 - BOOK MARK button (26)
 - PLAY MODE button (21 - 23)
 - CLEAR button (17, 21, 23, 26)
 - REPEAT button (24)
- 11 SOUND MODE button (12)
- 12 Karaoke operating buttons
 - VOCAL MASKING button (41)
 - ECHO button (39)
 - MODE button (40, 41)
 - KARAOKE button (39 - 41)
- 13 TAPE A/B button (36)
- 14 DISC SKIP button (15, 16)
- 15 TITLE button (20)
- 16 SUBTITLE button (19)
- 17 AUDIO/MPX button (19, 41)
- 18 ON SCREEN button (16, 17)
- 19 RETURN button (20, 21, 23, 28 - 35)
- 20 ANGLE button (19)
- 21 TAPE button (10, 36)
 - Pressing this button also turns on the unit.
- 22 FM/AM button (10, 13)
 - Pressing this button also turns on the unit.
- 23 DVD button (10, 15, 16, 21, 23, 25, 26, 39)
 - Pressing this button also turns on the unit.
- 24 (stop) button (15, 21, 23, 36)
- 25 VOLUME + button (11)
- 26 ENTER button (17, 20 - 23, 25 - 35)
- 27 FM MODE button (13)
- 28 FADE MUTING button (11)
- 29 SUBWOOFER LEVEL + / - buttons (11)
- 30 3D SOUND button (12)

How to open the front lid

Press center part of the lid and pull down.

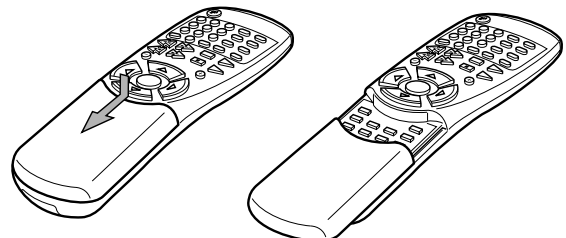

Unpacking

After unpacking, check to be sure that you have all the following items.

The number in the parentheses indicates the quantity of the pieces supplied.

- AM loop antenna (1)
- FM antenna (1)
- Remote control (1)
- Batteries (2)
- Composite video cord (1)
- AC plug adaptor (1)

If any is missing, consult your dealer immediately.

Putting the Batteries into the Remote Control

Insert the batteries — UM-4/AAA/IEC R03 — into the remote control, by matching the polarity (+ and -) on the batteries with the + and - markings on the battery compartment.

When the remote control can no longer operate the unit, replace both batteries at the same time.

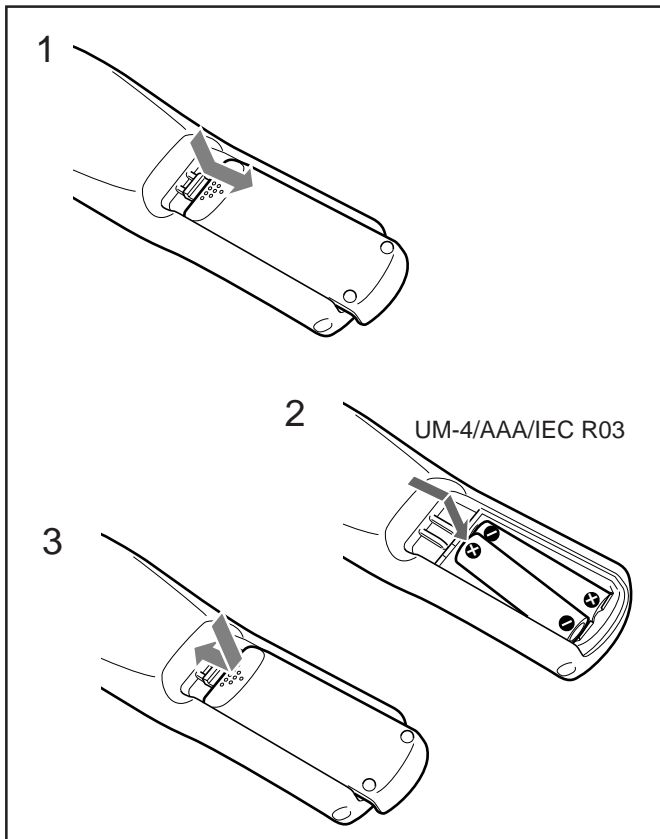

- DO NOT use an old battery together with a new one.
- DO NOT use different types of batteries together.
- DO NOT expose batteries to heat or flame.
- DO NOT leave the batteries in the battery compartment when you are not going to use the remote control for an extended period of time. Otherwise, it will be damaged from battery leakage.

Connecting Antennas

FM antenna

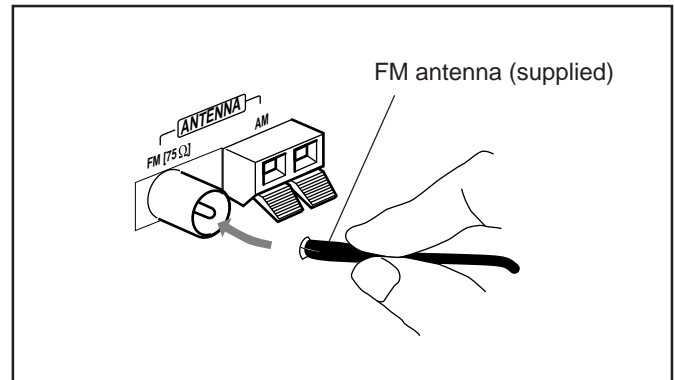

- 1 Attach the FM antenna to the FM [75 Ω] coaxial terminal.
- 2 Extend the FM antenna.
- 3 Fasten it up in the position which gives you the best reception, then fix it on the wall, etc.



About the supplied FM antenna

The FM antenna supplied with this unit can be used as temporary measure. If reception is poor, you can connect an outdoor FM antenna.

To connect an outdoor FM antenna

Before connecting it, disconnect the supplied FM antenna.

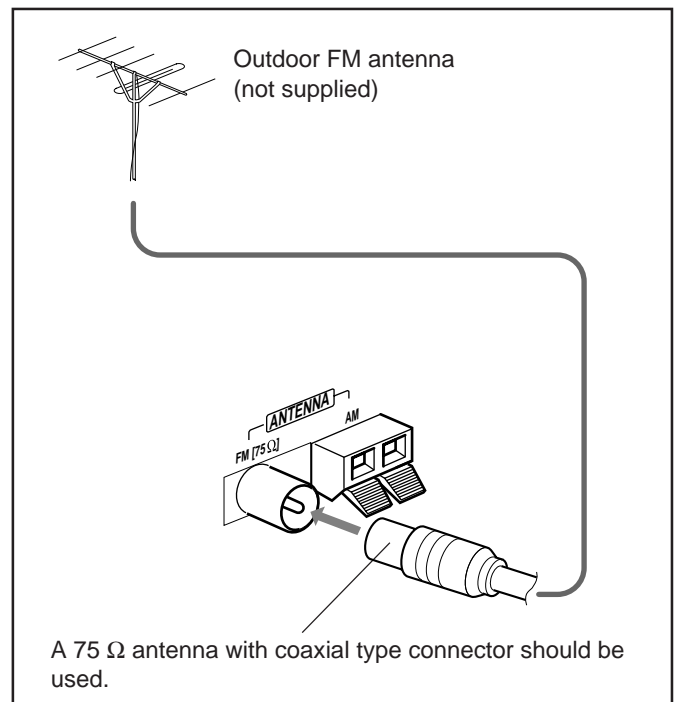

AM antenna

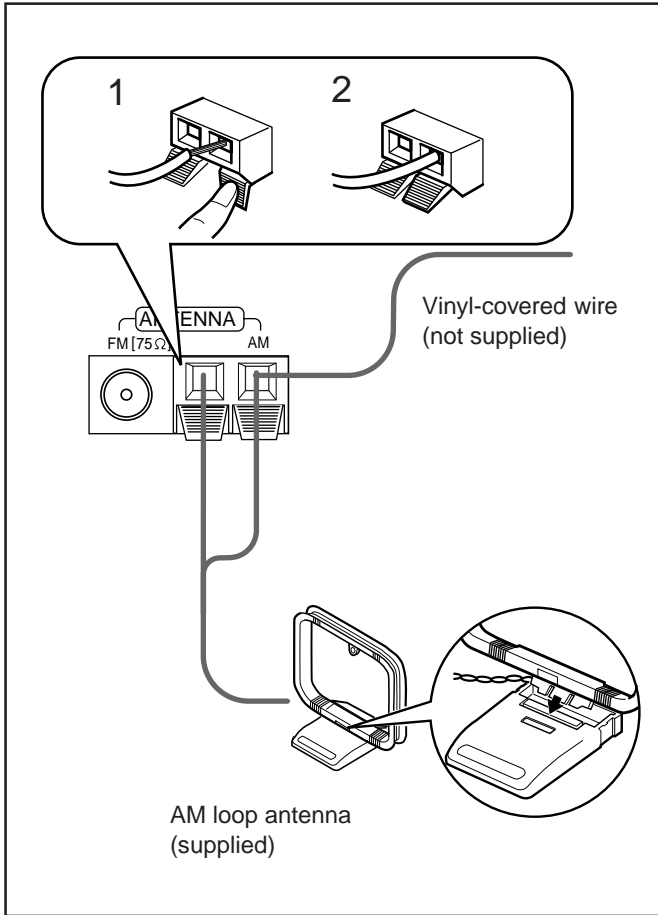

- 1 Press and hold the clamp of the AM terminals on the rear of the unit.
- 2 Insert the end of the AM loop antenna cord into the terminal.
- 3 Release the finger from the clamp.
- 4 Turn the AM loop antenna until you have the best reception.

To connect an outdoor AM antenna

When reception is poor, connect a single vinyl-covered wire to the AM terminal and extend it horizontally. (The AM loop antenna must remain connected.)



For better reception of both FM and AM

- Make sure the antenna conductors do not touch any other terminals and connecting cords.
- Keep the antennas away from metallic parts of the unit, connecting cords, and the AC power cord.

Connecting Speakers

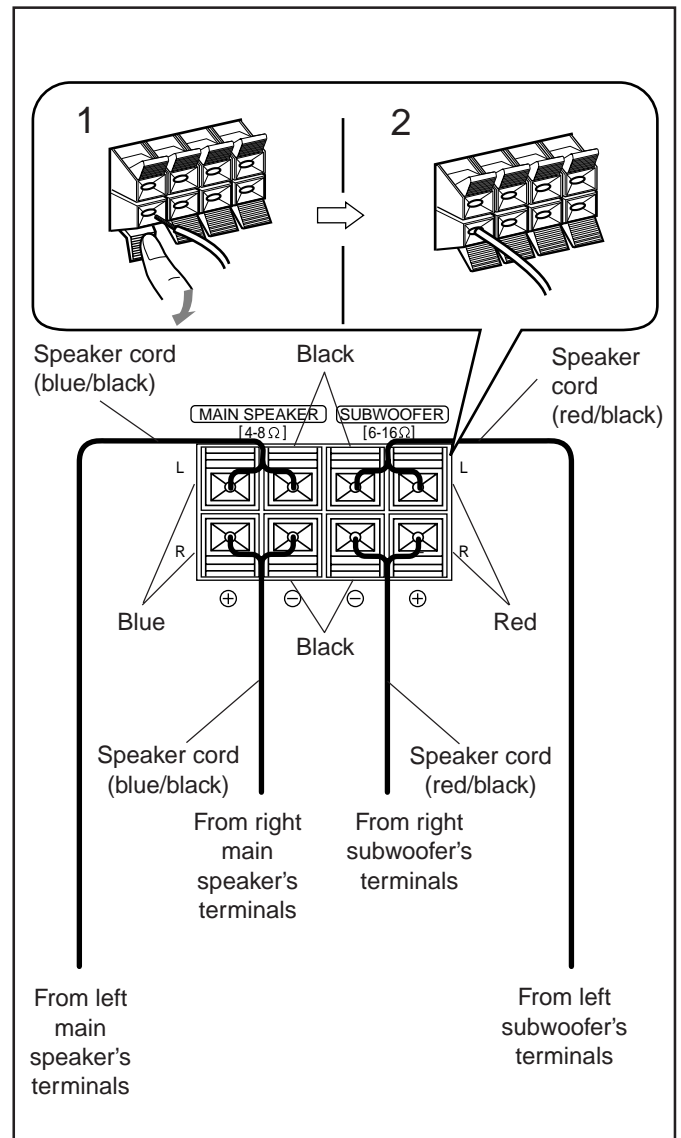

- 1 Press and hold the clamp of the speaker terminal on the rear of the unit.
- 2 Insert the end of the speaker cord into the terminal.
Match the polarity (colors): Blue (+) to blue (+) and black (-) to black (-); Red (+) to red (+) and black (-) to black (-).
- 3 Release the finger from the clamp.

IMPORTANT: Use only speakers with the same speaker impedance as indicated by the speaker terminals on the rear of the unit.

Connecting Other Equipment

You can connect both analog and digital equipment.



- DO NOT connect any equipment while the power is on.
- DO NOT plug in any equipment until all connections are complete.

To connect analog components

Be sure that the plugs of the audio cords are color coded: White plugs and jacks are for left audio signals, and red ones for right audio signals.

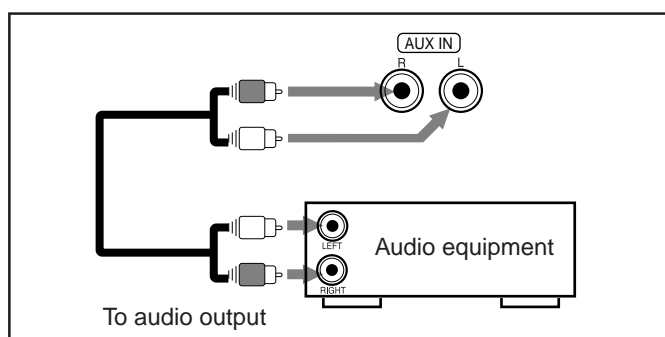

For playing the other equipment through this unit, connect between the audio output jacks on the other equipment and the AUX IN jacks by using an audio cord (not supplied).

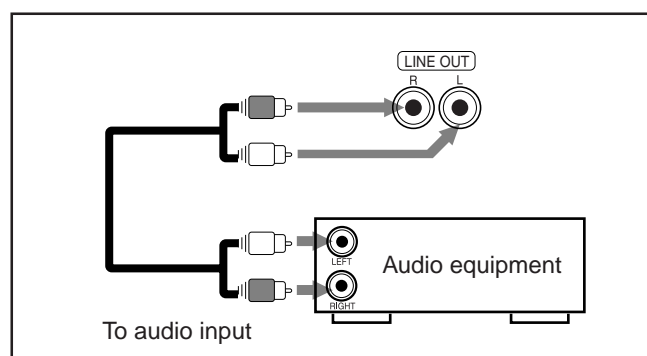

For recording sounds through this unit on the other equipment, connect between the audio input jacks on the other equipment and the LINE OUT jacks by using an audio cord (not supplied).

- See “About sounds reproduced through the rear terminals” on the right column.

To connect audio equipment with an optical digital input terminal — such as digital decoder

You can connect a digital decoder or MD recorder by using an optical digital cord (not supplied).

- See “About sounds reproduced through the rear terminals” below.

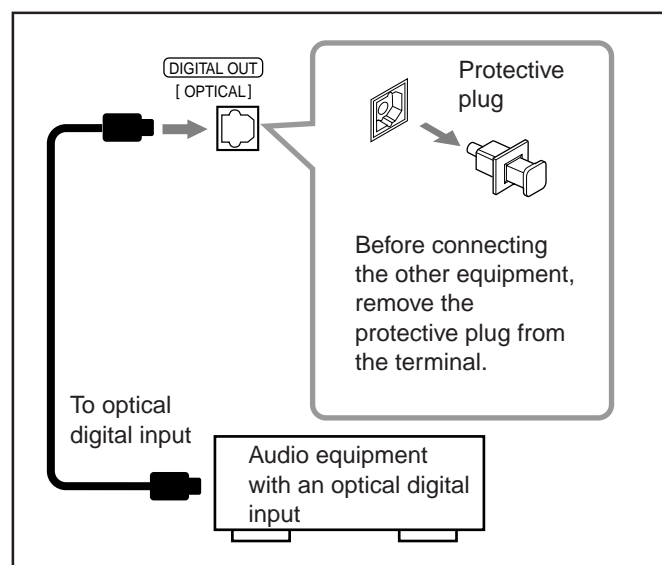

About sounds reproduced through the rear terminals

• Through the LINE OUT (L/R) jacks and MAIN SPEAKERS/SUBWOOFER terminals:

Analog stereo signals are output.

When playing a source encoded with Dolby Digital* (DOLBY DIGITAL) or with MPEG Multichannel, multichannel signals are mixed to the left and right front channel signals, then output.

– You cannot reproduce the sound encoded DTS Digital Surround** (DTS SURROUND).

• Through the DIGITAL OUT (OPTICAL) terminal:

Digital signals (Linear PCM, Dolby Digital, DTS Digital Surround, MPEG Multichannel) are output through this terminal.

To reproduce the multichannel sounds such as Dolby Digital, MPEG Multichannel, and DTS Digital Surround, connect an amplifier or a decoder compatible with these multichannel sources to this terminal, and set “DIGITAL OUTPUT” and “DTS” settings correctly. (See page 31.)

* Manufactured under license from Dolby Laboratories. “Dolby” and the double-D symbol are trademarks of Dolby Laboratories. Confidential Unpublished Works. ©1992–1997 Dolby Laboratories. All rights reserved.

** Manufactured under license from Digital Theater Systems, Inc. US Pat. No. 5,451,942 and other world-wide patents issued and pending. “DTS” is a registered trademark of Digital Theater Systems, Inc. Copyright 1996, 2000 Digital Theater Systems, Inc. All Rights Reserved.

To connect the TV

Connect your TV and this unit using the composite video cord (supplied) or an S-video cord (not supplied).

- Using an S-video cord gives you a better quality pictures.

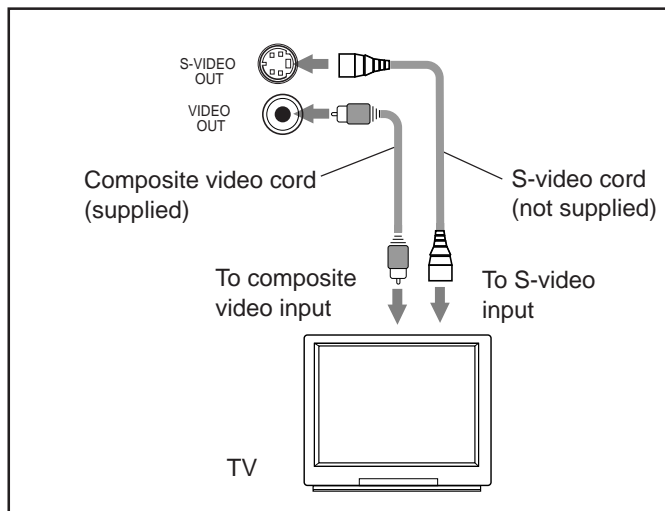

NOW, you can plug in the unit and other connected equipment FINALLY!

When connecting the AC power cord into a wall outlet, the unit automatically starts display demonstration.

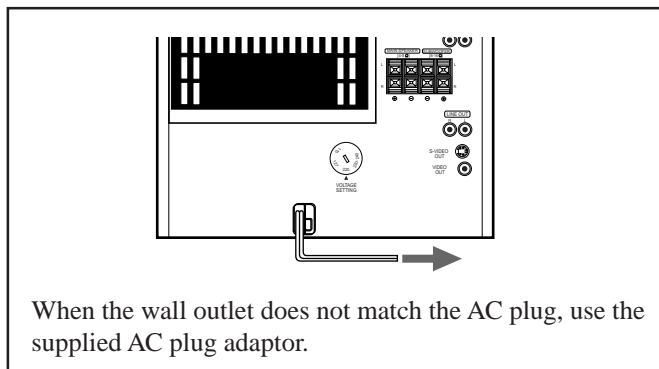

Adjusting the Voltage Selector

Before plugging in the unit, set the correct voltage for your area with the voltage selector on the rear of the unit.



- DO NOT plug in before setting the voltage selector on the rear of the unit and all connection procedures are complete.

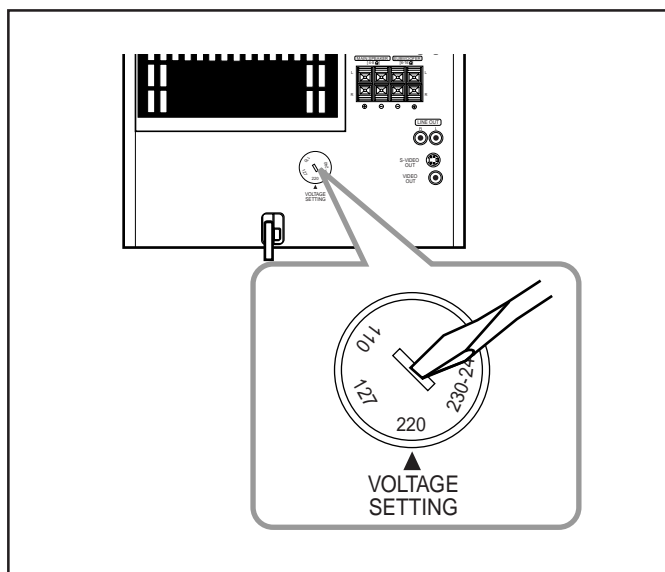

Using a screwdriver, set the voltage selector so that the arrow printed on the rear points the correct voltage where you use this unit. (See also the back cover page.)

Canceling the Display Demonstration

On the unit ONLY:

To cancel the display demonstration, press DEMO.



When you press other buttons

The display demonstration stops temporarily. It will start automatically again (if no operation is done for 2 minutes) until you cancel it by pressing DEMO.

To start the display demonstration manually

Press and hold DEMO again for more than 2 seconds.

Turning On or Off the Power

To turn on the unit, press

 STANDBY/ON so that the STANDBY lamp goes off.

WELCOME

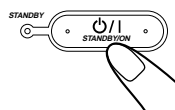

To turn off the unit (on standby), press

 STANDBY/ON again so that the STANDBY lamp lights up.

GOOD BYE

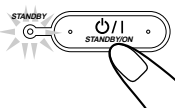

A little power is always consumed even while the unit is on standby.

To switch off the power supply completely, unplug the AC power cord from the AC outlet.



When you unplug the AC power cord or if a power failure occurs

The clock is reset to “-- : --,” while the tuner preset stations (see page 13) will be erased in a few days.

Setting the Clock

Before operating the unit any further, first set the clock built in this unit. You can set the clock whether the unit is on or off.

On the unit ONLY:

1 Press **CLOCK/TIMER**.

0:00



The hour digits start flashing on the display.

2 Press **◀◀** or **▶▶** to adjust the hour, then press **SET**.

1:00

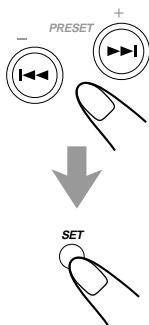

- If you want to correct the hour after pressing SET, press CANCEL. The hour digits start flashing again.

3 Press **◀◀** or **▶▶** to adjust the minute, then press **SET**.

CLOCK OK

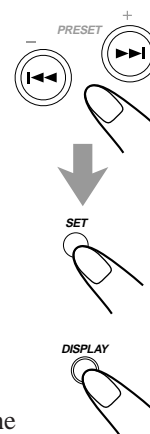

To check the clock time

Press DISPLAY while playing any source.

- Each time you press the button, the source indication and the clock time alternate on the display.

To adjust the clock again

If you have adjusted the clock before, you need to press CLOCK/TIMER repeatedly until “CLOCK” is selected.

- Each time you press the button, the clock/timer setting modes change as follows:

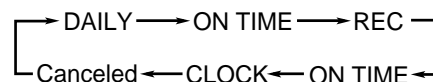

If there is a power failure

The clock loses the setting and is reset to “-- : --.” You need to set the clock again.

Selecting the Sources



To listen to the FM/AM broadcasts, press FM/AM. (See page 13.)

To play back discs, press DVD . (See pages 14 – 35.)

To play back tapes, press TAPE  . (See page 36.)

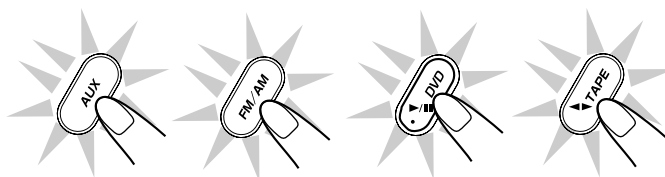
To select the external equipment as the source, press AUX.



When you press the play button for a particular source (AUX, FM/AM, DVD , and TAPE  ), the unit turns on and the unit starts playing the source if it is ready.

Adjusting the Volume

You can adjust the volume level only while the unit is turned on.

Turn the VOLUME control clockwise to increase the volume or counterclockwise to decrease it.

- The volume level can be adjusted in 32 steps (VOL MIN, VOL 1 — VOL 30, and VOL MAX).

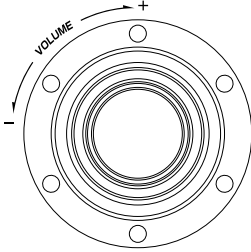

VOL 15

When using the remote control, press VOLUME + to increase the volume or press VOLUME - to decrease it.



For private listening

Connect a pair of headphones to the PHONES jack. No sound comes out of the speakers. Be sure to turn down the volume before connecting or putting on headphones.



DO NOT turn off (on standby) the unit with the volume set to an extremely high level; otherwise, a sudden blast of sound can damage your hearing, speakers and/or headphones when you turn on the unit or start playing any source next time. REMEMBER you cannot adjust the volume level while the unit is on standby.

To turn down the volume level temporarily

Press FADE MUTING on the remote control. The volume level gradually decreases to "VOL MIN."

To restore the sound, press the button again.



Reinforcing the Bass Sound

This function only affects the playback sound, but does not affect your recording.

Turn the SUBWOOFER LEVEL control clockwise to increase the subwoofer sound or counterclockwise to decrease it.

- The subwoofer level can be adjusted in 4 steps (LEVEL 1 — LEVEL 4.) If you turn the control clockwise up to the subwoofer LEVEL 4, "MAX" flashes on the display for a few seconds.

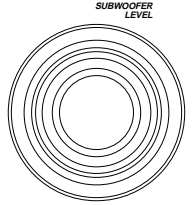

SUBWOOFER LEVEL indicator always lights up when the unit is on.

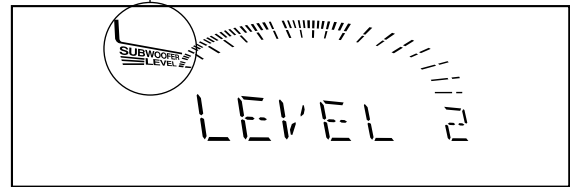

When using the remote control, press SUBWOOFER LEVEL to adjust the subwoofer level. The subwoofer level changes as LEVEL 1 → LEVEL 2 → LEVEL 3 → LEVEL 4 → (back to the beginning).

Selecting the Sound Modes

This function only affects the playback sound, but does not affect your recording.

You can select one of the 6 preset sound modes (3 surround modes and 3 SEA — Sound Effect Amplifier — modes).

To select the sound modes, turn the SOUND MODE control until the sound mode you want appears on the display.

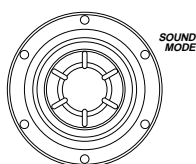

SOUND MODE indicator also lights up on the display

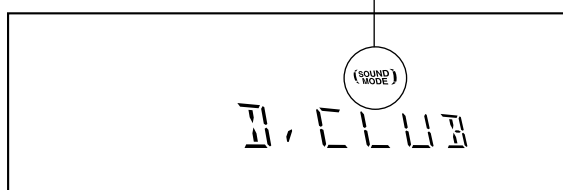

- As you turn the control, the sound modes change as follows:

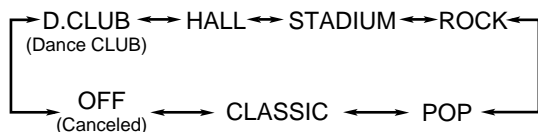

Surround modes*:

D.CLUB: Increases resonance and bass.

HALL: Adds depth and brilliance to the sound.

STADIUM: Adds clarity and spreads the sound, like in an outdoor stadium.

SEA (Sound Effect Amplifier) modes:

ROCK: Boosts low and high frequency. Good for acoustic music.

POP: Good for vocal music.

CLASSIC: Good for classical music.

OFF: Cancels the sound mode.

* Surround elements are added to the SEA elements to create a being-there feeling in your room.

When one of these modes is selected, the SOUND MODE indicator lights up as — **(SOUND MODE)**

While one of the SEA modes (SEA elements without surround elements) is selected, the SOUND MODE indicator lights up as — **SOUND MODE**

When using the remote control, press SOUND MODE to adjust the sound mode.

- Each time you press the button, the sound modes change as follows:

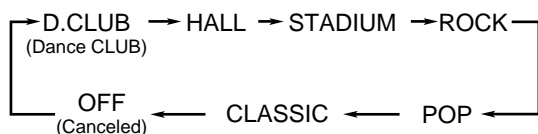

Creating a Being-There Feeling

By adding breadth and depth the reproduced sounds, this function (3D Sound) can create a being-there feeling while playing back software encoded with Dolby Digital or with MPEG Audio.

- When the Digital Output setting is set to Bitstream on the Setup Menu (see page 31), this function does not work.

On the remote control ONLY:

1 Press 3D SOUND during play.

The current 3D Sound setting appears on the TV screen.



- If “3-D SOUND : ON” appears on the TV screen, now 3D Sound function is in use, press 3D SOUND again to erase the indication.

2 Press Cursor ► (or ◀) to turn on 3D Sound function.

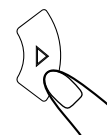

3 Press 3D SOUND again to erase the indication.

To turn off 3D Sound, repeat the above procedure and in step 2, select “OFF.”



Setting the AM Tuner Interval Spacing

Some countries space AM stations 9 kHz apart, and some countries use 10 kHz spacing.

On the unit ONLY:

When shipped, the unit is set to 10 kHz spacing.

To select 9 kHz, press **⏻/|** while holding down **◀◀** when the unit is in standby mode. “AM -- 9” appears on the display.

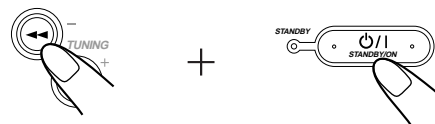

To change back to 10 kHz interval, press **⏻/|** while holding down **▶▶** when the unit is in standby mode. “AM -- 10” appears on the display.

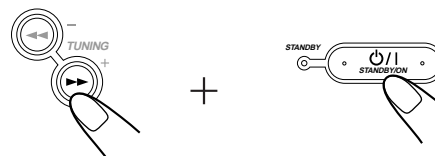

Listening to FM and AM Broadcasts

Before operating the tuner, make sure you have selected the correct AM spacing intervals (see page 12).

Tuning in a Station

1 Press FM/AM.

The unit automatically turns on and tunes in the previously tuned station (either FM or AM).

- Each time you press the button, the band alternates between FM and AM.



2 Start searching for stations.

On the unit:

Press and hold TUNING + or TUNING – for more than 1 second.

On the remote control:

Press and hold ◀◀ or ▶▶ for more than 1 second.

The unit starts searching for stations and stops when a station of sufficient signal strength is tuned in.

If a program is broadcast in stereo, the ST (stereo) indicator lights up.

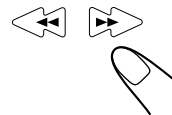
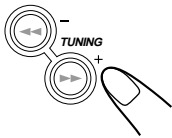

To stop during searching, press TUNING + or TUNING – (or ◀◀ or ▶▶ on the remote control).



When you press TUNING + or TUNING – (or ◀◀ or ▶▶ on the remote control) briefly and repeatedly

The frequency changes step by step.

To change the FM reception mode

When an FM stereo broadcast is hard to receive or noisy, press FM MODE on the remote control so that “MONO” appears and the MONO indicator also lights up on the display. Reception improves.

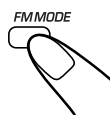

To restore the stereo effect, press FM MODE again so that “STEREO” appears on the display and the MONO indicator goes off from the display.

In this stereo mode, you can hear stereo sounds when a program is broadcast in stereo.

Presetting Stations

You can preset 30 FM and 15 AM stations.

In some cases, test frequencies have been already memorized for the tuner since the factory examined the tuner preset function before shipment. This is not a malfunction. You can preset the stations you want into memory by following the presetting method.

- There is a time limit in doing the following steps. If the setting is canceled before you finish, start from step 1 again.

On the unit ONLY:

1 Tune in the station you want to preset.

- See “Tuning in a Station” on the left column.

F-M 87.50

2 Press SET.

SET

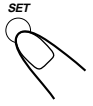

3 Press PRESET + or PRESET – to select a preset number.

F-01

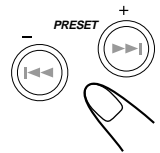

4 Press SET again.

STORED

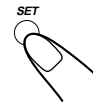

The tuned station in step 1 is stored in the preset number selected in step 3.

- Storing a new station on a used number erases the previously stored one.



When you unplug the AC power cord or if a power failure occurs

The preset stations will be erased in a few days. If this happens, preset the stations again.

Tuning in a Preset Station

1 Press FM/AM.

The unit automatically turns on and tunes in the previously tuned station (either FM or AM).

- Each time you press the button, the band alternates between FM and AM.

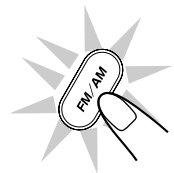

2 Select a preset number.

On the unit:

Press PRESET + or PRESET –.

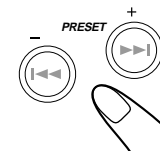

On the remote control:

Press the number buttons.

Ex.: For preset number 5, press 5.

For preset number 15, press 10, then 5.

For preset number 20, press 10 twice (and wait for a few seconds.)



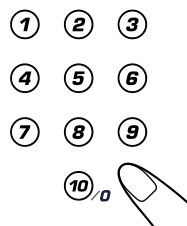

For preset number 30, press 10 three times (and wait for a few seconds.)



DVD Introduction

This unit has been designed to playback the following discs: DVD, Video CD, and Audio CD.

Discs you can play:

Disc Type	Mark (Logo)	Video Format	Region Code Number*
DVD Video		NTSC or PAL	3 ALL
			
Video CD	 Video CD		_____
S-Video CD			_____
Audio CD		_____	_____

- On some discs, their actual operations may be different from what is explained in this manual.
- The following discs cannot be played back;
 - DVD-Audio, DVD-ROM, DVD-RAM, DVD-R, DVD-RW, CD-ROM, CD-R, CD-RW, CD-I, (CD-I Ready), Photo CD, etc.
 Playing back these discs will generate noise and damage the speakers.

* Note on Region Code

DVD players and DVD Video discs have their own Region Code numbers. This unit only can play back DVD discs whose Region Code numbers include “3.”

Examples:



IMPORTANT: Before performing any operations, make sure of the following....

- Check the connection with the TV.
- Turn on the TV and select the correct input on the TV to view the pictures or on-screen indications on the TV screen.
- For DVD playback, you can change the Setup menu setting to your preference. (See pages 28 – 35.)

If “⊗” appears on the screen when pressing a button, the disc cannot accept an operation you have tried to do.

Disc structure — DVD, Video CD (VCD) and Audio CD (CD)

A DVD disc consists of **Titles**, and each title may be divided into some **Chapters**. (See Example 1.)

For example, if a DVD disc contains some movies, each movie may have its own title number, and it may be further divided into some chapters.

On the other hand, a VCD or CD consists of **Tracks**. (See Example 2.)

In general, each song has its own track number. (On some discs, each track may also be divided by Indexes.)

When playing back a VCD with Playback Control (PBC) function, you can select what to view using the menu shown on the TV screen. (While operating a Video CD using the menu, some of the functions such as Repeat and Track Search may not work.)

Example 1: DVD disc

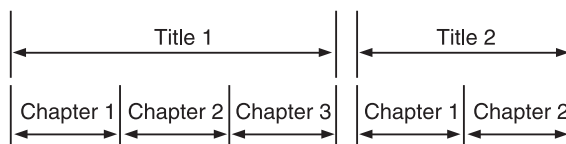

Example 2 : Video CD/Audio CD

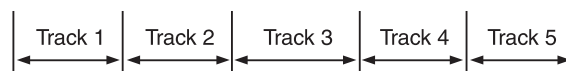

Basic Disc Playback

Before playing a DVD or VCD, select the color system as indicated on the disc.

On the unit only:

Press TAPE A while the unit is in standby mode. Each time you press the button, "PAL," "NTSC," and "SECAM" appear on the display in sequence.



About the color system

When wrong color system is selected, picture on TV screen will lose the color.

Loading Discs

1 Press .

The unit automatically turns on and the carousel comes out.



2 Place one or two discs correctly on the front slots of the carousel, with its label side up.

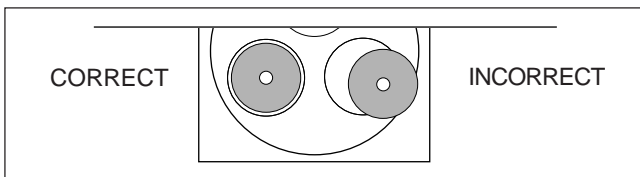

- When using a CD single (8 cm), place it on the inner circle of the disc tray.
- Continued use of irregular shape CDs (heart-shape, octagonal, etc.) can damage the unit.

3 If you wish to load a third disc, press DISC CHANGE on the unit or DISC SKIP on the remote control.

The carousel rotates by 120°.



4 Press again.

The carousel closes.



About the disc indicators

Each disc indicator corresponds to the disc tray of the same number.

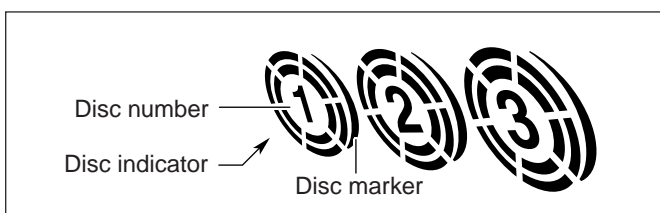

- The disc marker lights up for the disc number you have selected.
- The disc indicator rotates while the corresponding disc is being played.
- The disc indicator goes off when the unit has detected that there is no disc on the corresponding disc tray.

Playing Back the Entire Discs — Continuous Play

You can play discs continuously.

- While playing a DVD or VCD with the PBC function loaded on the disc trays, the continuous play will stop when a disc menu appears. **If a menu appears while playing a DVD or VCD with PBC function, see "Menu-Driven Playback" on page 20.**

1 Load discs.

2 Press one of the disc number buttons (DVD1, DVD2, and DVD3) for the disc you want to play.

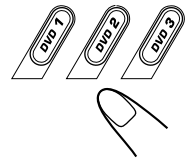

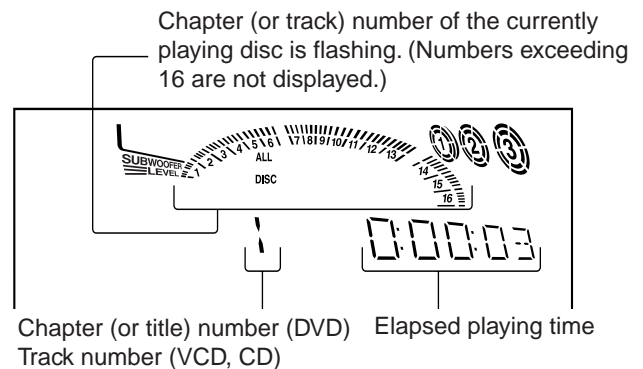

Disc play starts from the first chapter or track of the selected disc.



- Pressing DVD  instead of the disc number buttons starts playing back if a disc is on the trays.

To stop during play, press .

- If you are playing back a disc, this unit can memorize the end point even when you turn off the unit, and when you start playback again by pressing DVD , playback begins from where it has been stopped. (Resume play)
- To stop completely, press  twice.

To remove the disc, press .



Disc playback sequence during Continuous play

When 3 discs are loaded on the disc trays, they are played in one of the following sequences.

- When DVD1 is pressed : DVD1 ⇒ DVD2 ⇒ DVD3 (then stops)
- When DVD2 is pressed : DVD2 ⇒ DVD3 ⇒ DVD1 (then stops)
- When DVD3 is pressed : DVD3 ⇒ DVD1 ⇒ DVD2 (then stops)
- * When only 2 discs are loaded, they are played in the same order, but the disc tray without a disc is skipped.

Basic Disc Operations

While playing a disc, you can do the following operations.

To exchange discs during playback of another

Press DISC CHANGE to change the disc and the carousel comes out. 

If you change discs during play, the current play will not stop until all discs you have changed are played.

To close the carousel, press DISC CHANGE or .

To skip to another disc in the carousel

Press DISC SKIP on the remote control. 

- Pressing DVD1, DVD2, or DVD3 will also skip to the selected disc tray.

To stop play for a moment



Press DVD  (or STILL while playing a DVD or VCD).



While pausing, "PAUSE" appears on the display.

- A still picture appears while playing a DVD or VCD. You can advance the still picture frame by frame by pressing the STILL on the remote control repeatedly. (See page 25.) 

To resume play, press DVD  again.

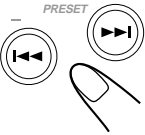
To go to another chapter or track

Press  or  repeatedly before or during playback. 

- : Goes back to the beginning of the current or previous chapters/tracks.
- : Skips to the beginning of the next or succeeding chapters/tracks.



If you press and hold  /  on the unit before playing

You can change the chapters or tracks continuously.

To go to another track directly using the number buttons (only possible on a CD and VCD)

Pressing the number buttons (two digits) before or during play allows you to start playing the track number you want.

- To select number 5, press 0, 5 (or simply press 5, and wait for a few seconds).
- To select number 10, press 1, 0.
- To select number 23, press 2, 3.

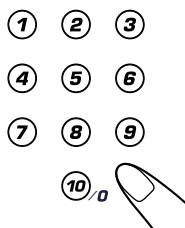

Showing the On-Screen Display

You can show the following information on the TV screen while a disc is loaded, and change the title, chapter or track if you want on the screen.

- When playing a VCD using the PBC function, the on-screen information cannot be shown.

To show the disc information, press ON SCREEN on the remote control. 

Each time you press the button, the following information appears in sequence.

When a DVD is loaded:

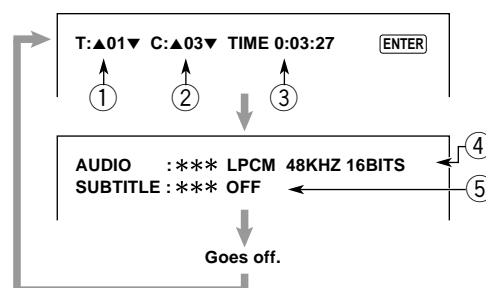

- Current title number
 - ▲/▼ indicates that you can move to another title by pressing ▲/▼ when the title number is highlighted. See page 17 for details.
- Current chapter number
 - ▲/▼ indicates that you can move to another chapter by pressing ▲/▼ when the chapter number is highlighted. See page 17 for details.
- Elapsed playing time of the current chapter
 - You can move to a particular portion of the current chapter using this displayed time. See page 17 for details.
- Audio language and Sound mode
 - Audio language indicates whether the disc contains audio languages. (Ex.: When no audio language is recorded on the disc. See page 19 for more details.)
 - Sound mode indicates the signal type — Linear PCM (stereo), Dolby Digital, MPEG Multichannel, and DTS Digital Surround (Ex.: When the disc is recorded in the Linear PCM format)
- Subtitle selection of the current disc (Ex.: When no subtitle language is recorded on the disc. See page 19 for more details.)

When a VCD without the PBC function or CD is loaded:

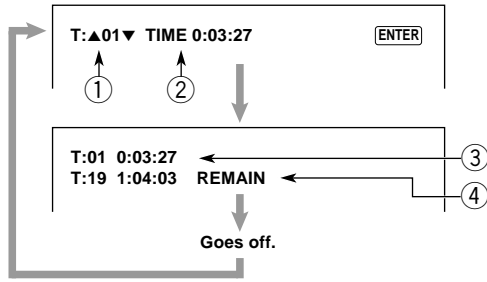

- ①: Current Track number
- ▲/▼ indicates that you can move to another track by pressing ▲/▼ when the track number is highlighted. See below for details.
- ②: Elapsed playing time of the current track
- You can move to a particular portion of the current track using this displayed time. See below for details.
- ③: Current Track number and its elapsed playing time
- ④: Remaining track number and remaining time of the disc

Locating a particular point directly using the screen indication

You can use the following Search Modes to locate a particular portion directly while playing a disc.

- For DVD: Title Search, Chapter Search, and Time Search
- For VCD and CD: Track Search and Time Search

On the remote control ONLY:

1 Press ON SCREEN once.

The on-screen indication appears.

ON SCREEN



When a DVD is playing:

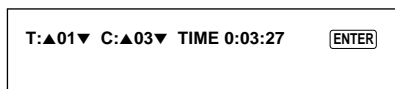

When a VCD without the PBC function or CD is playing:

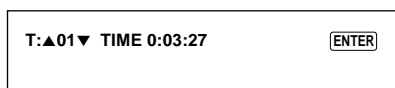

2 Press Cursor ► (or ◀) so that your desired item is highlighted.

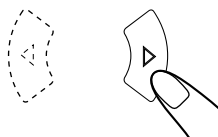

3 Press the number buttons to select a desired title, chapter, track or playing time, then press ENTER.

The unit starts playback of the selected item.

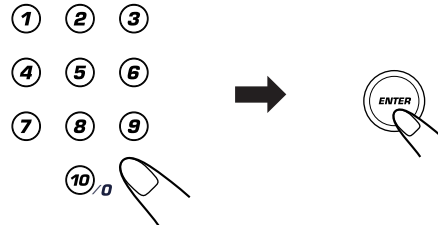

How to input the title, chapter, and track number

Press the number buttons corresponding to the number, then press ENTER to start its playback.

- To select number 5, press 5, then ENTER.
- To select number 10, press 1, 0, then ENTER.
- To select number 23, press 2, 3, then ENTER.

* You can also use ▼ or ▲ to select the number (then press ENTER).

How to input the playing time

Press the number buttons to input the playing time, then press ENTER to start playback at the selected elapsed playing time.

- To input time "00:45:23," press 4, 5, 2, 3, then ENTER.
- To input time "01:23:45," press 1, 2, 3, 4, 5, then ENTER.

- To cancel a mis-entry, press CLEAR.

Each time you press the button, the last entry will be erased.

Searching for a Particular Point

You can search for a particular portion while playing a disc — Forward/Reverse Search.

Forward Search

To fast-forward the chapter or track, press **▶▶** while playing a disc.

- Each time you press the button, the search speed changes as follows (and appears on the TV screen):

When a DVD is playing:

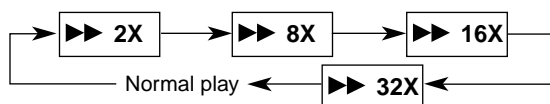

- No sound comes out during 8X (times), 16X, and 32X Speed Search.
- When “2X SCAN AUDIO” is “ON,” sounds come out during 2X Speed Search. (See page 32.)

When a VCD or CD is playing:

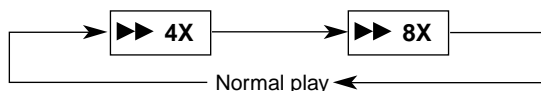

- No sound comes out during Speed Search.

Reverse Search

To reverse the chapter or track, press **◀◀** while playing a disc.

Each time you press the button, the search speed changes as follows:

When a DVD is playing:

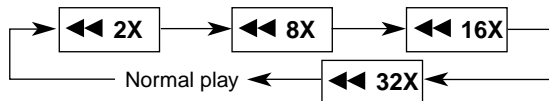

When a VCD or CD is playing:

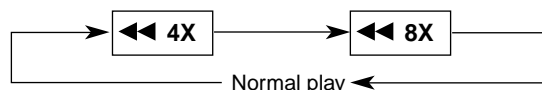

When playing a DVD or VCD

No sound comes out during Reverse Search.

Prohibiting Disc Ejection — Tray Lock

You can prohibit disc ejection from the unit and can lock discs.

- This operation is possible only while the unit is on with disc selected as the source.

On the unit ONLY:

To prohibit disc ejection, press **▲** for the carousel while holding **■**.

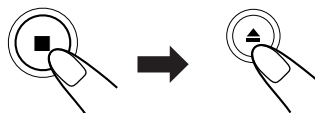

“LOCKED” appears for a while, and the carousel is locked.

To cancel the prohibition and unlock the discs, press **▲** for the carousel while holding **■**.

“UNLOCKED” appears for a while, and the carousel is unlocked.





If you try to eject discs

“LOCKED” appears to inform you that the Tray Lock is in use.

DVD Playback

Some DVDs contain several audio languages, subtitles, and multi-angle views.

When you find the following marks on the DVD or its package, you can select these elements recorded on the DVD.

	Subtitles are recorded on the disc. The number inside the mark indicates the total number of the recorded subtitles.
	Several audio languages are recorded on the disc. The number inside the mark indicates the total number of the recorded audio languages.
	Multi-angle views are recorded on the disc. The number inside the mark indicates the total number of the recorded multi-angle views.

Selecting the Subtitles

While playing a disc containing subtitles in different languages, you can select the subtitle to be displayed on the screen.

- You can set your favorite subtitle language as the initial language shown on the screen. (See page 29.)

On the remote control ONLY:

1 Press SUBTITLE.

The on-screen indication appears on the TV screen.



2 Press Cursor ▼ (or ▲) to select a desired subtitle language.

- Each time you press the button, the subtitle language changes.

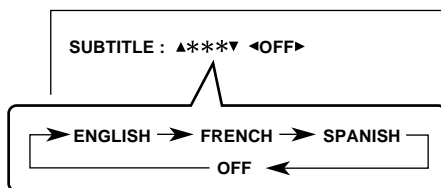
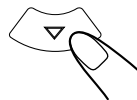

Ex.: When the disc has 3 selections — English, French, Spanish and no subtitle (OFF)

Selecting the Audio Languages

While playing a disc containing audio languages (sound tracks), you can select the language (sound) to listen to.

- You can set your favorite audio language as the initial audio language. (See page 29.)

On the remote control ONLY:

1 Press AUDIO/MPX.

The on-screen indication appears on the TV screen.



2 Press Cursor ▼ (or ▲) to select a desired audio language.

- Each time you press the button, the audio language changes.

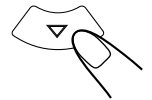

Signal encoding format also appears.

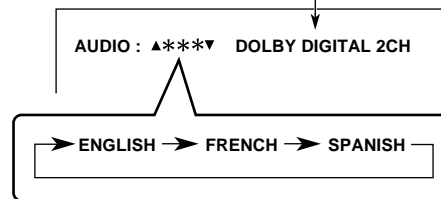

Ex.: When the disc has 3 selections — English, French, and Spanish

Selecting the Multi-Angle Views

While playing a disc containing multi-angle views, you can view the same scene at different angles.

- To show (or not to show) the angle mark on the TV screen while playing back a disc containing multi-angle views, see page 34.

On the remote control ONLY:

1 Press ANGLE.

The on-screen indication appears on the TV screen.

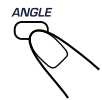

2 Press Cursor ▼ (or ▲) to select a desired multi-angle view.

- Each time you press the button, the view angle changes.

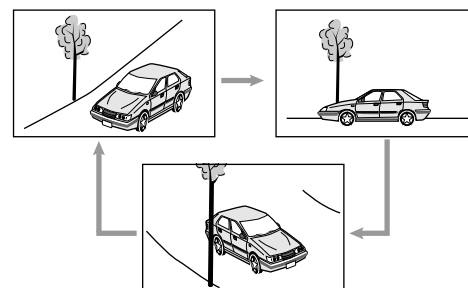
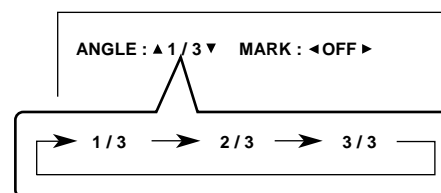

Ex.: When the disc has 3 multi-angle views

Menu-Driven Playback

Menu Operations

Menu-driven playback is possible while playing back a DVD with menu-driven features or a VCD with the PBC function.

While playing a DVD:

DVD discs generally have their own menus or title lists. A menu usually contains various information about the disc and playback selections. On the other hand, a title list usually contains titles of movies and songs recorded.

On the remote control ONLY:

1 Press MENU/PBC or TITLE.

A menu or title list will appear on the screen.

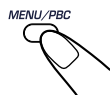

2 Select a desired item on the menu or on the title list, using Cursor buttons (▲/▼/▶/◀) and ENTER.

The unit starts playback of the selected item.

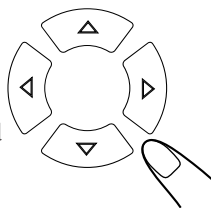

- On some discs, you can also select items by pressing the Number buttons corresponding to the item numbers listed.

To erase the menu or title list

Press MENU/PBC or TITLE again (or repeatedly until it goes off).

- If “⊗” appears on the screen when pressing MENU/PBC in step 1, the disc does not have a menu.
- If “⊗” appears on the screen when pressing TITLE in step 1, the disc does not have a title list.

While playing a VCD:

The Playback Control function (PBC) allows you to operate the VCD using menus.

When you start playback, a menu will automatically appear on the screen.

- A menu may be a list of items, divided screens, or some moving pictures. (See “PBC operation concept” on the right column.)

Select a desired item on the menu.

- When a list of items is displayed on the screen, press the Number buttons to select an item.
- When “▶” or “SELECT” is displayed on the screen, press DVD ▶/|| to start playback.

How to select items using the number buttons

- To select number 5, press 0, 5 (or press 5, then wait for a few seconds).
- To select number 10, press 1, 0.
- To select number 23, press 2, 3.

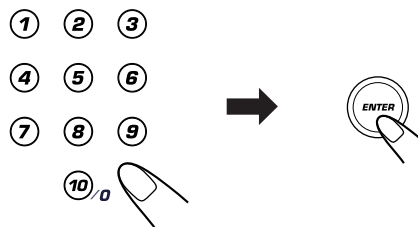

To go to the next menu

Press NEXT.

To return to the previous menu

Press PREV. or RETURN.

To cancel the PBC playback

You can cancel the menu-driven operations (PBC function):

- 1 Press ■ to stop playback.
 - 2 Press the Number buttons to select a track.
Normal playback starts from the selected track.
- You can also turn on and off the PBC playback by pressing MENU/PBC on the remote control repeatedly.

PBC operation concept

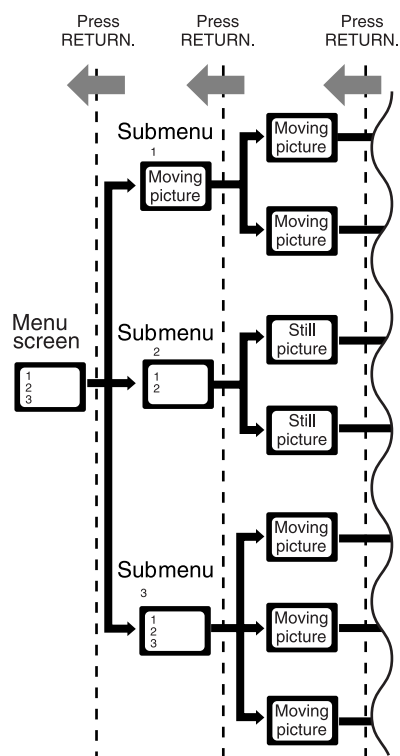

Selecting Playback Modes

Programming the Playing Order of the Chapters or Tracks — Program Play

You can arrange the order in which the titles, chapters, or tracks play before you start playing. **You can program up to 20 steps.**

- To use Repeat play (see page 24) for Program play, press REPEAT after starting Program play.

When making a program using a DVD:

You can select either Title Program or Chapter Program.

On the remote control ONLY:

1 Load a disc.

- If the current playing source is not the DVD player, press DVD1, DVD2 or DVD3 on the unit to select the disc you want to play, then **■** before going to the next step.

2 Press PLAY MODE.

The following screen appears on the TV.

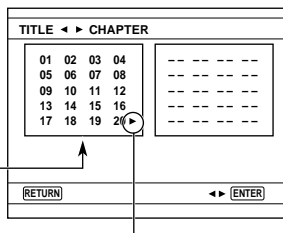

Titles or chapters in the selected disc

Appears when you can go to the next page (another title or chapter number list—starting with number 21).

The PRGM (program) indicator also lights up on the display (the TITLE or CHAP.TRACK indicator also lights up.)

3 Press Cursor **▶** (or **◀**) to select (highlight) either “TITLE” or “CHAPTER,” then press ENTER.

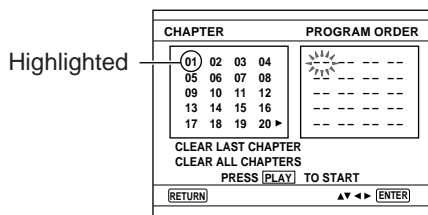
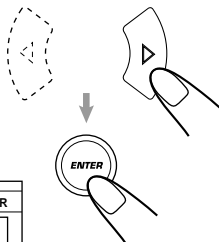

Ex.: when selecting Chapter Program.

4 Press Cursors **▶** (or **▼**, **◀**, **▲**) to select (highlight) the chapter (or title) number, then press ENTER.

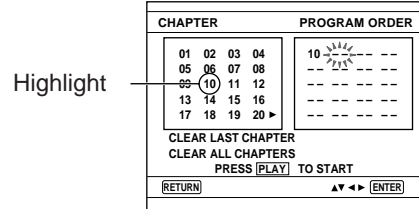
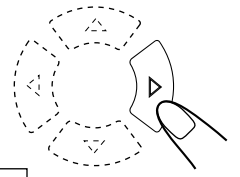

Ex.: when selecting chapter number 10.

- You can also press number buttons to select the chapter (or title) numbers. See “To go to another track directly using the number buttons” on page 16.

Appears when you can go back to the previous page (chapter or title number list).

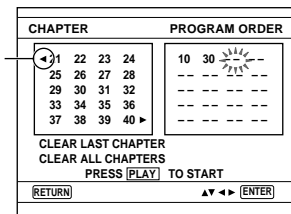

Ex.: when selecting chapter number 30.

5 Repeat step 4 to program other chapters (or titles) you want.

After 20 tracks are programmed, “CLEAR LAST CHAPTER (or TITLE)” is selected.

- If you want to play back the programmed chapters (or titles), go to step 6.
- If you want to modify the program, go to page 22.

6 Press DVD **▶/II**.

The chapters (or titles) are played in the order you have programmed.



To stop during play, press **■**.

- If you are playing back a DVD, this unit can memorize the end point even when you turn off the unit, and when you start playback again by pressing DVD **▶/II**, playback begins from where it has been stopped. (Resume play)
- To stop completely, press **■** twice.

To exit from Program play mode while setting the program, press PLAY MODE or RETURN. (The program you have made is also erased.)

- To exit from Program play during or after play, press CLEAR.
- Ejecting a carousel will also erase the stored memory.

To modify the program

Before playing, you can modify the program.

To erase the last chapter (or title): press Cursor ▼ to select (highlight) “CLEAR LAST CHAPTER (or TITLE),” then press ENTER.

- Each time you press ENTER, the last programmed chapter (or title) is erased from the program.

To erase all the programmed chapters (or titles): press Cursor ▼ to select (highlight) “CLEAR ALL CHAPTERS (or TITLES),” then press ENTER.

To add chapters (or titles) in the program before play, simply select the chapter (or title) numbers you want to add by following step 4.

To check the programmed contents

After playing, you can check the programmed contents by pressing PLAY MODE. The programmed contents appear on the TV screen.



If your entry is ignored

You have tried to program a chapter (or title) number that does not exist on the disc. Such entries are ignored.



You can cancel the program after play by pressing following buttons:

1. DISC CHANGE, Disc number buttons (DVD1, DVD2, DVD3), ▲ or ■ (twice) on the unit, or
2. CLEAR on the remote control.

When making a program using a CD or VCD:

On the remote control ONLY:

1 Load a disc.

- If the current playing source is not the DVD player, press DVD1, DVD2 or DVD3 on the unit to select the disc you want to play, then ■ before going to the next step.

2 Press PLAY MODE.

The following screen appears on the TV.

- Make sure that “PROGRAM” on the TV screen is highlighted. If “RANDOM” is highlighted, press Cursor ◀ to highlight “PROGRAM.”

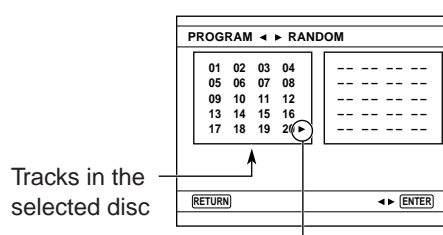

Tracks in the selected disc

Appears when you can go to the next page (another track number list — starting with number 21).

The PRGM (program) indicator also lights up on the display.

3 Press ENTER.

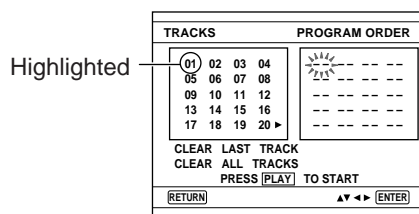

Highlighted

4 Press Cursors ▶ (or ▼, ◀, ▲) to select (highlight) the track number, then press ENTER.

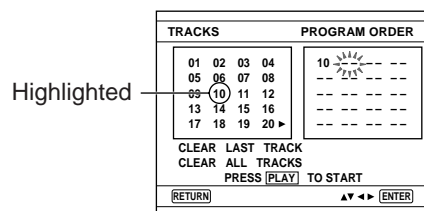
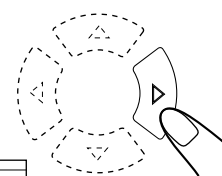

Highlighted

Ex.: when selecting track number 10.

- You can also press Number buttons to select the track numbers. See “To go to another track directly using the number buttons” on page 16.

5 Repeat steps 4 to program other tracks you want.

After 20 tracks are programmed, "CLEAR LAST TRACK" is selected.

- If you want to play back the programmed tracks, go to step 6.
- If you want to modify the program, see below.

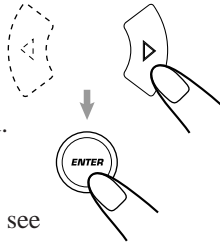

Appears when you can go back to the previous page (track number list).

TRACKS				PROGRAM ORDER			
21	22	23	24	10	30	☀	
25	26	27	28	---	---	---	---
29	30	31	32	---	---	---	---
33	34	35	36	---	---	---	---
37	38	39	30▶	---	---	---	---

CLEAR LAST TRACK
CLEAR ALL TRACKS
PRESS [PLAY] TO START

[RETURN] [ENTER]

Ex.: when selecting track number 30.

6 Press DVD ►/II.

The tracks are played in the order you have programmed.



To stop during play, press ■.

- If you are playing back a VCD or CD, this unit can memorize the end point even when you turn off the unit, and when you start playback again by pressing DVD ►/II, playback begins from where it has been stopped. (Resume play)
- To stop completely, press ■ twice.

To exit from Program play mode while setting the program, press PLAY MODE or RETURN. (The program you have made is also erased.)

- To exit from Program play mode during or after play, press CLEAR.
- Ejecting a carousel will also erase the stored memory.

To modify the program

Before playing, you can modify the program.

To erase the last track: press Cursor ▼ to select (highlight) "CLEAR LAST TRACK," then press ENTER.

- Each time you press ENTER, the last programmed track is erased from the program.

To erase all the programmed tracks: press Cursor ▼ to select (highlight) "CLEAR ALL TRACKS," then press ENTER.

To add tracks in the program before play, simply select the track numbers you want to add by following step 4.

To check the programmed contents

After playing, you can check the programmed contents by pressing PLAY MODE. The programmed contents appear on the TV screen.



If your entry is ignored

You have tried to program a track number that does not exist on the disc. Such entries are ignored.



You can cancel the program after play by pressing following buttons:

1. DISC CHANGE, Disc number buttons (DVD1, DVD2, DVD3), ▲ or ■ (twice) on the unit, or
2. CLEAR on the remote control.

Playing at Random — Random Play

The tracks of the selected disc will play at random.

- Random play cannot be used on a DVD.
- To use Repeat play for Random play, press REPEAT after starting Random play.

On the remote control ONLY:

1 Load a disc.

- If the current playing source is not the DVD player, press DVD1, DVD2 or DVD3 on the unit to select the disc you want to play, then ■ before going to the next step.

2 Press PLAY MODE.

The following screen appears on the TV.

- Make sure that "RANDOM" on the TV screen is highlighted. If "PROGRAM" is highlighted, press Cursor ► to highlight "RANDOM."



PROGRAM ◀ ▶ RANDOM							
01	02	03	04	---	---	---	---
05	06	07	08	---	---	---	---
09	10	11	12	---	---	---	---
13	14	15	16	---	---	---	---
17	18	19	20▶	---	---	---	---

[RETURN] [ENTER]

The RANDOM indicator also lights up on the display.

To cancel Random play mode, press PLAY MODE or RETURN.

3 Press ENTER (or DVD ►/II).

The tracks are played at random. Random play ends when all tracks are played once.



To stop during play, press ■.

- Random play also stops when ▲ is pressed.

To exit from Random play mode when finished, press CLEAR.



If you press ►►► or ◀◀◀

Skips to the next track selected randomly.

Repeating Playback

Repeat Play

You can repeat a title, chapter, track, or disc.

- Repeat play cannot be used on a VCD with the PBC function.
- To use Repeat play for Program play and Random play, press REPEAT after starting playback.

To repeat playback, press REPEAT while playing or pausing.

The on-screen indication appears on the TV screen.

- Each time you press the button, the repeat mode indication on the TV screen changes as follows: (The respective REPEAT indicators also light up on the display.)



When a DVD is playing:

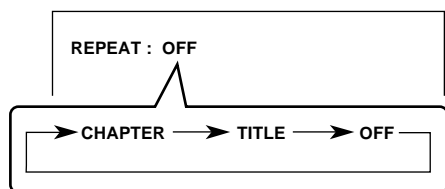

- CHAPTER*: Current chapter will be repeated.
- TITLE**: Current title will be repeated.
- OFF: Repeat play is canceled. (Continuous play mode is resumed. See page 15.)

* During Title program play, you cannot select "CHAPTER" repeat.

** During Chapter program play, you cannot select "TITLE" repeat.

When a CD or VCD without the PBC function is playing:

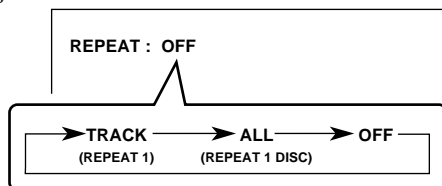

- TRACK: Current track will be repeated.
- ALL: Current disc will be repeated.
- OFF: Repeat play is canceled. (Continuous play mode is resumed. See page 15.)

A-B Repeat

While playing, you can also select a portion you want to repeat.

- When playing a DVD, A-B Repeat is not performed between different chapters or different titles.
- A-B Repeat cannot be used on a VCD with the PBC function.

On the unit ONLY:

1 Press A-B REPEAT to select the start point.

The following on-screen indication appears on the TV screen.

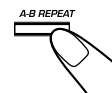

- "RPT A-" also appears on the display.

2 Press A-B REPEAT again to select the end point.

A-B Repeat begins.

The unit automatically locates point A and starts repeated playback of the portion between points A and B.

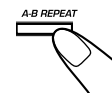

- "RPT A-B" also appears on the display.



To cancel A-B Repeat, press A-B REPEAT again.



- "RPT A-B" goes off from the display.

If "⊘" appears on the screen when pressing A-B REPEAT in step 1, A-B Repeat cannot be used on the selected portion.

- On some DVDs, A-B Repeat may not be used even within the same chapter. This is due to their disc structures, and not a malfunction of the unit.

Special Effects Playback

Still Picture/Frame-by-frame Playback

You can advance the still picture frame by frame while playing back a DVD or a VCD.

On the remote control ONLY:

1 Press STILL once during play.

A still picture appears on the screen.

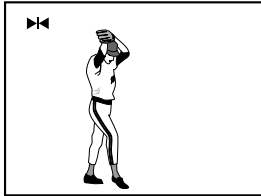

2 Press STILL repeatedly to advance the picture frame by frame.

- Each time you press the button, the picture advances frame by frame.



To resume normal play

Press DVD ►/||.



If the picture shakes or small letters cannot be clearly shown during still picture playback

Change "STILL MODE" setting using the Setup menu (see page 34).

Slow Motion Playback

You can enjoy slow motion playback while playing a DVD or VCD.

- Reverse slow motion playback is only possible on a DVD.

1 Press DVD ►/|| (or STILL) once during play.

A still picture appears on the screen.

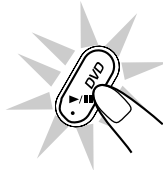

2 Press ►► (or ◀◀) repeatedly to start slow-motion playback

- Each time you press ►►, slow motion speed changes as follows:

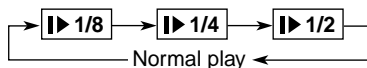

- Each time you press ◀◀, reverse slow motion speed changes as follows (only possible on a DVD):

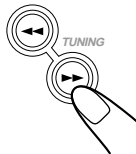
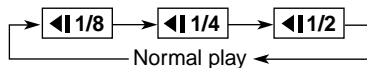

Zoom

You can zoom up a particular portion of the picture while playing a DVD and VCD.

On the remote control ONLY:

1 Press ZOOM.

The zoom scope appears on the center of the TV screen.

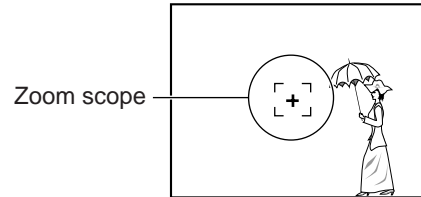
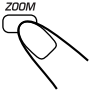

2 Press Cursor (◀, ▶, ▲, ▼) to move the zoom scope to the portion you want to zoom in.

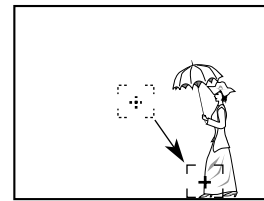
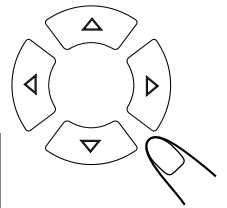

3 Press ENTER to zoom into the portion selected in the above step.

- Each time you press the button, the picture is enlarged as follows:



When a DVD is playing:

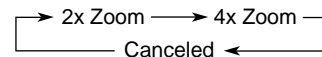

When a VCD is playing:

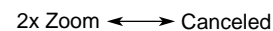

The following function is possible only using the remote control.

Marking the Scenes You Want — Bookmark

You can mark any scene while playback, and later go back to the marked scene.

- This function can be used on a DVD or on a VCD without the PBC function. (This function may not work even on a DVD or on a VCD without the PBC function due to its disc structure.)

■ Putting the Bookmarks Where You Want

You can mark up to three scenes which you can locate later.

1 Press BOOK MARK during playback.

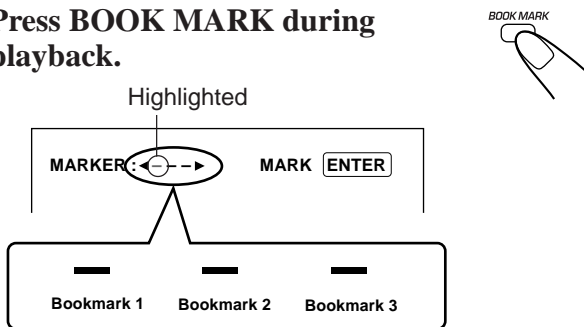

2 Press > (or <) to select (highlight) the bookmark number position (1, 2, 3) you want.

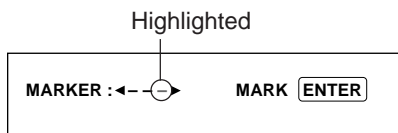

Ex. When you select bookmark number position 3.

3 When you reach the scene you want to mark, press ENTER.

Bookmark number appears (in this case 3.)

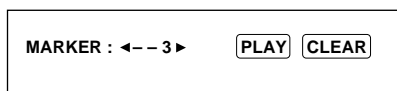

4 Repeat steps 2 and 3 to mark other scenes you want.

To erase the on-screen indication, press BOOK MARK again.

■ Locating Marked Scenes

You can locate marked scenes very easily by selecting one of the bookmarks.

1 Press BOOK MARK during playback.

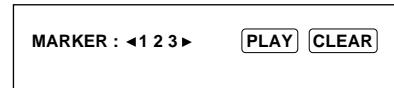

2 Press Cursor > (or <) to select (highlight) the book mark number (1, 2, 3) you want.

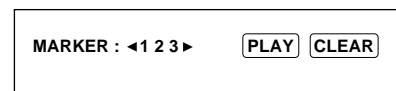

3 Press DVD >/II.

Playback skips to the marked scene.

■ Erasing Bookmarks

1 Press BOOK MARK during playback.



2 Press Cursor > (or <) to select (highlight) the book mark number (1, 2, 3) you want to erase.



3 Press CLEAR.

The selected bookmark number disappears.

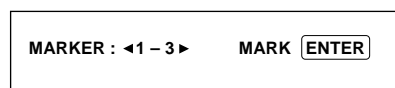

Ex. When bookmark 2 is erased.

To erase the on-screen indication, press BOOK MARK again.

Viewing tracks of a VCD

You can view the beginning of each track of a disc (Track View) or 9 scenes of the selected track on a disc (Index View) and locate it directly.

- This function can be used on a VCD without the PBC function.

On the remote control ONLY:

1 Press TITLE during playback.

The “DISC VIEW” screen appears on the TV screen.

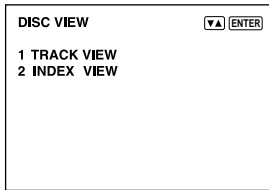

2 Press Cursor ▼ (or ▲) to select (highlight) either “TRACK VIEW” or “INDEX VIEW,” then press ENTER.



- TRACK VIEW: To view the beginning of each track on a disc. 9 tracks will be shown at a time. If a disc has more than 9 tracks, pressing NEXT will show other 9 tracks on the screen.
- INDEX VIEW: To view 9 scenes of the current playing track. These scenes are created by dividing the track equally into 9 portions and the beginning (5 seconds each) of those 9 scenes are shown on the TV screen.



When selecting “TRACK VIEW”:

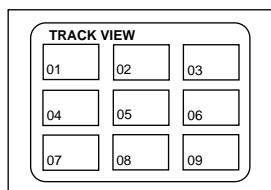

When selecting “INDEX VIEW”:

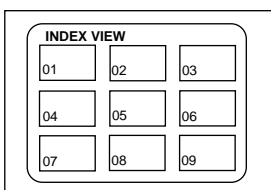

3 Press Cursor ▼ (or ▲, ►, ◀) to select (highlight) a scene you want to start playback, then press ENTER.

Playback skips to the selected scene.



If you press TITLE before starting play “TRACK VIEW” screen appears.



If you press TITLE during DVD play or CD play During DVD play, the title screen of the DVD disc will appear. (See page 20.)

During CD play, the first 10 seconds of each track will be played back. When all the tracks are played, normal playback starts from the first track.

You can store the initial selection for subtitle languages, audio languages (sound), and other settings using the Setup menu.

- Setup menu can only be displayed while a disc is not playing.
- You can only use the remote control for Setup menu operations.

Setting the Setup Menu Language

You can select the language for the Setup menu.

To go back to the previous screen during the procedure, press RETURN.

1 Press SETUP.

Setup menu appears on the TV screen.

SETUP MENU	
1 PLAYER MENU	ENGLISH
2 DISC MENU	ENGLISH
3 AUDIO	ENGLISH
4 SUBTITLE	ENGLISH
5 PARENTAL	UNLOCKED 
6 AUDIO OPTIONS	
7 DISPLAY OPTIONS	
(RETURN) ▼▲ (ENTER)	

2 Press Cursor ▼ (or ▲) to select (highlight) “1 PLAYER MENU,” then press ENTER.

► indicates the current setting

PLAYER MENU LANGUAGE	
► 1 ENGLISH	
2 FRANCAIS	
3 DEUTSCH	
4 ESPAÑOL	
5 ITALIANO	
6 NEDERLANDS	
(RETURN) ▼▲ (ENTER)	

3 Press Cursor ▼ (or ▲) to select (highlight) the language you want, then press ENTER.

Setup menu are now shown in the selected language.

To erase the Setup menu, press RETURN repeatedly until the Setup menu disappears.

Setting the Initial Disc Language

You can select the initial language for the disc menu.

However, in the following cases, the original language will be selected as the initial language regardless of your setting.

- If the language you have selected is not recorded on the disc.
- If the disc is programed to be played back in the original language.

To go back to the previous screen during the procedure, press RETURN.

1 Press SETUP.

Setup menu appears on the TV screen.

2 Press Cursor ▼ (or ▲) to select (highlight) “2 DISC MENU,” then press ENTER.

SETUP MENU	
1 PLAYER MENU	ENGLISH
2 DISC MENU	ENGLISH
3 AUDIO	ENGLISH
4 SUBTITLE	ENGLISH
5 PARENTAL	UNLOCKED 
6 AUDIO OPTIONS	
7 DISPLAY OPTIONS	
(RETURN) ▼▲ (ENTER)	



DISC MENU LANGUAGE	
► 1 ENGLISH	
2 FRANCAIS	
3 DEUTSCH	
4 ESPAÑOL	
5 ITALIANO	
6 NEDERLANDS	
7 OTHERS	
(RETURN) ▼▲ (ENTER)	

3 Press Cursor ▼ (or ▲) to select (highlight) the language you want, then press ENTER.

- If the language you want is not listed, select “7 OTHERS,” then press ENTER.

The following sub-language screen appears.

DISC MENU LANGUAGE	
► CESKY	AFRIKAANS
DANSK	ARABIC
MAGYAR	CHINESE
SVENSKA	GREEK
NORSK	HINDI
POLSKY	JAPANESE
PORTUGUES	RUSSIAN
SUOMI	TURKISH
(RETURN) ▼▲ (ENTER)	

Then, press Cursor ▼ (or ▲) to select the language you want, then press ENTER.

To erase the Setup menu, press RETURN repeatedly until the Setup menu disappears.

Setting the Initial Audio Language

You can select the initial language for audio sound. However, in the following cases, the original language will be selected as the initial language regardless of your setting.

- If the language you have selected is not recorded on the disc.
- If the disc is programmed to be played back in the original language.

To go back to the previous screen during the procedure, press RETURN.

1 Press SETUP.

Setup menu appears on the TV screen.

2 Press Cursor ▼ (or ▲) to select (highlight) “3 AUDIO,” then press ENTER.

SETUP MENU	
1 PLAYER MENU	ENGLISH
2 DISC MENU	ENGLISH
3 AUDIO	ENGLISH
4 SUBTITLE	ENGLISH
5 PARENTAL	UNLOCKED
6 AUDIO OPTIONS	
7 DISPLAY OPTIONS	

↓

AUDIO LANGUAGE	
▶ 1 ENGLISH	
2 FRANCAIS	
3 DEUTSCH	
4 ESPAÑOL	
5 ITALIANO	
6 NEDERLANDS	
7 ORIGINAL	
8 OTHERS	

3 Press Cursor ▼ (or ▲) to select (highlight) the language you want, then press ENTER.

- If you want to listen to the originally recorded language, select “7 ORIGINAL.”
- If the language you want is not listed, select “8 OTHERS,” then press ENTER.

The following sub-language screen appears.

AUDIO LANGUAGE	
▶ CESKY	AFRIKAANS
DANSK	ARABIC
MAGYAR	CHINESE
SVENSKA	GREEK
NORSK	HINDI
POLSKY	JAPANESE
PORTUGUES	RUSSIAN
SUOMI	TURKISH

Then, press Cursor ▼ (or ▲) to select the language you want, then press ENTER.

To erase the Setup menu, press RETURN repeatedly until the Setup menu disappears.

Setting the Initial Subtitle Language

You can select the initial language for subtitles. However, in the following cases, the original language will be selected as the initial language regardless of your setting.

- If the language you have selected is not recorded on the disc.
- If the disc is programmed to be played back in the original language.

To go back to the previous screen during the procedure, press RETURN.

1 Press SETUP.

Setup menu appears on the TV screen.

2 Press Cursor ▼ (or ▲) to select (highlight) “4 SUBTITLE,” then press ENTER.

SETUP MENU	
1 PLAYER MENU	ENGLISH
2 DISC MENU	ENGLISH
3 AUDIO	ENGLISH
4 SUBTITLE	ENGLISH
5 PARENTAL	UNLOCKED
6 AUDIO OPTIONS	
7 DISPLAY OPTIONS	

↓

SUBTITLE LANGUAGE	
▶ 1 AUTOMATIC	
2 ENGLISH	
3 FRANCAIS	
4 DEUTSCH	
5 ESPAÑOL	
6 ITALIANO	
7 NEDERLANDS	
8 OTHERS	

3 Press Cursor ▼ (or ▲) to select (highlight) the language you want, then press ENTER.

- If you want to show the same language as the initial audio language, select “1 AUTOMATIC.”
- If the language you want is not listed, select “8 OTHERS,” then press ENTER.

The following sub-language screen appears.

SUBTITLE LANGUAGE	
▶ CESKY	AFRIKAANS
DANSK	ARABIC
MAGYAR	CHINESE
SVENSKA	GREEK
NORSK	HINDI
POLSKY	JAPANESE
PORTUGUES	RUSSIAN
SUOMI	TURKISH

Then, press Cursor ▼ (or ▲) to select the language you want, then press ENTER.

To erase the Setup menu, press RETURN repeatedly until the Setup menu disappears.

Setting the Parental Level

Using this function, you can restrict playback of DVD containing violent scenes (and those not suitable for your family members).

- This function is only possible for the DVDs containing such rating level information (Level 1 to Level 8.)

To go back to the previous screen during the procedure, press RETURN.

1 Press SETUP.

Setup menu appears on the TV screen.

2 Press Cursor ▼ (or ▲) to select (highlight) “5 PARENTAL,” then press ENTER.

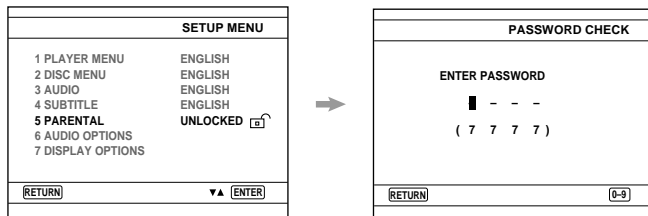

3 Press the number buttons to enter the password (4 digits).

- When shipped from the factory, password is “7777” (it is shown on the display when you set this function for the first time.)

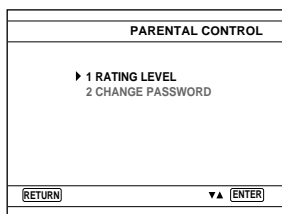

- If you enter a wrong password, “WRONG PASSWORD!” appears.

4 Press Cursor ▼ (or ▲) to select (highlight) “1 RATING LEVEL,” then press ENTER.

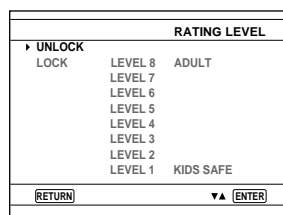

5 Press Cursor ▼ (or ▲) to select (highlight) the level you want, then press ENTER.

- If you do not want to make any restriction, select “UNLOCK.”

To erase the Setup menu, press SETUP again.

■ To change the password

1 Press SETUP.

Setup menu appears on the TV screen.

2 Press Cursor ▼ (or ▲) to select (highlight) “5 PARENTAL,” then press ENTER.

3 Press the number buttons to enter the password.

- If you enter a wrong password, “WRONG PASSWORD!” appears.

4 Press Cursor ▼ (or ▲) to select (highlight) “2 CHANGE PASSWORD,” then press ENTER.

5 Press the number buttons to enter a new password.

The password confirmation screen appears.

6 Press the number buttons to re-enter the new password.

To erase the Setup menu, press RETURN repeatedly until the Setup menu disappears.

■ When you forget the password

1 Press DUBBING for a few seconds while the unit is turned on and the DVD is selected as the source.

Language selection menu appears on the TV screen.

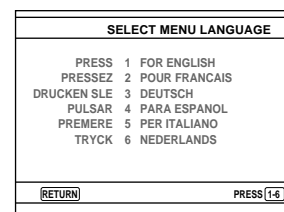

2 Press the number button on the remote control to select the same language as used for the Setup menu.

3 The password is back to the factory setting of “7777.”

Setting the Digital Audio Output

When connecting an amplifier or a decoder to the DIGITAL OUT terminal, set it as recommended — Linear PCM or Bitstream.

To go back to the previous screen during the procedure, press RETURN.

1 Press SETUP.

Setup menu appears on the TV screen.

2 Press Cursor ▼ (or ▲) to select (highlight) “6 AUDIO OPTIONS,” then press ENTER.

Audio Options menu appears. (“1 DIGITAL OUTPUT” must be selected – highlighted.)

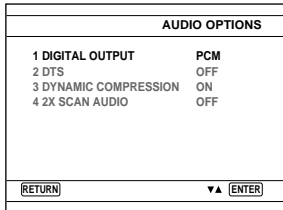
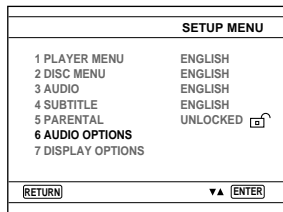

3 Press ENTER.

Digital Output selecting screen appears.

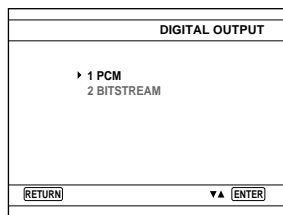

4 Press Cursor ▼ (or ▲) to select (highlight) an appropriate output, then press ENTER.

- **1 PCM:** Select this when connecting an amplifier or a decoder incompatible with Dolby Digital and with MPEG Multichannel.
- **2 BITSTREAM:** Select this when connecting an amplifier or a decoder compatible with Dolby Digital and with MPEG Multichannel.

To erase the Setup menu, press RETURN repeatedly until the Setup menu disappears.

Setting the DTS Signal Output

When connecting an amplifier or a decoder compatible with the DTS Digital Surround to the DIGITAL OUT terminal, set “DTS” setting to “ON.”

To go back to the previous screen during the procedure, press RETURN.

1 Press SETUP.

Setup menu appears on the TV screen.

2 Press Cursor ▼ (or ▲) to select (highlight) “6 AUDIO OPTIONS,” then press ENTER.

Audio Options menu appears. (“1 DIGITAL OUTPUT” must be selected – highlighted.)

3 Press Cursor ▼ (or ▲) to select (highlight) “2 DTS,” then press ENTER.

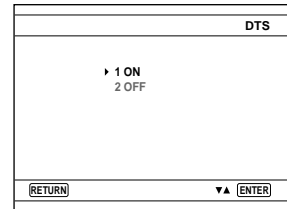
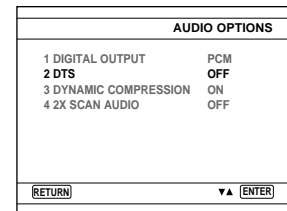

4 Press Cursor ▼ (or ▲) to select (highlight) an appropriate output, then press ENTER.

- **1 ON:** Select this when connecting an amplifier or a decoder compatible with DTS Digital Surround.
- **2 OFF:** Select this when connecting an amplifier or a decoder incompatible with DTS Digital Surround. (No digital signal comes out through the DIGITAL OUT terminal.)

To erase the Setup menu, press RETURN repeatedly until the Setup menu disappears.

Setting the Dynamic Compression

You can compress the dynamic range (difference between the maximum and minimum sound levels) while playing a source encoded with Dolby Digital. This is useful when listening at a low volume level.

To go back to the previous screen during the procedure, press RETURN.

1 Press SETUP.

Setup menu appears on the TV screen.

2 Press Cursor ▼ (or ▲) to select (highlight) "6 AUDIO OPTIONS," then press ENTER.

Audio Options menu appears. ("1 DIGITAL OUTPUT" must be selected – highlighted.)

3 Press Cursor ▼ (or ▲) to select (highlight) "3 DYNAMIC COMPRESSION," then press ENTER.

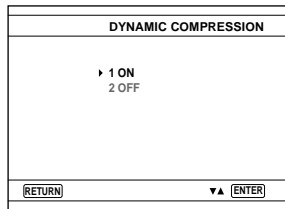
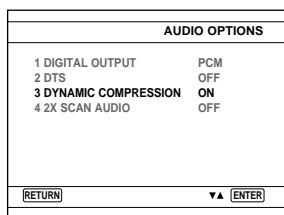

4 Press Cursor ▼ (or ▲) to select (highlight) a desired setting, then press ENTER.

- **1 ON:** Select this to apply dynamic compression.
- **2 OFF:** Select this not to apply dynamic compression (full dynamic range recorded as recorded on the original disc.)

To erase the Setup menu, press RETURN repeatedly until the Setup menu disappears.

Setting the Audio Output during 2X Speed Search

You can turn on or off the sound during 2X Speed Search on a DVD.

- Regardless of this setting, sound always comes out during 2X Speed Search on a CD.

To go back to the previous screen during the procedure, press RETURN.

1 Press SETUP.

Setup menu appears on the TV screen.

2 Press Cursor ▼ (or ▲) to select (highlight) "6 AUDIO OPTIONS," then press ENTER.

Audio Options menu appears. ("1 DIGITAL OUTPUT" must be selected – highlighted.)

3 Press Cursor ▼ (or ▲) to select (highlight) "4 2X SCAN AUDIO," then press ENTER.

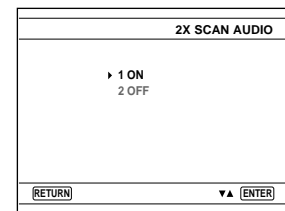
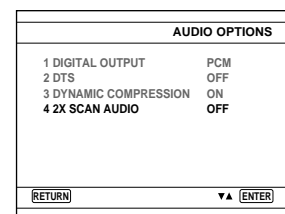

4 Press Cursor ▼ (or ▲) to select (highlight) a desired setting, then press ENTER.

- **1 ON:** Sounds come out during 2X Speed Search*.
- **2 OFF:** No sounds come out during 2X Speed Search.

* Some sounds will be skipped during 2X Speed Search.

To erase the Setup menu, press RETURN repeatedly until the Setup menu disappears.

Setting the TV Aspect

Set the monitor type when you watch a wide screen picture.

- This setting takes effect only when playing back a DVD recorded with 16:9 wide screen video signal.

To go back to the previous screen during the procedure, press RETURN.

1 Press SETUP.

Setup menu appears on the TV screen.

2 Press Cursor ▼ (or ▲) to select (highlight) “7 DISPLAY OPTIONS,” then press ENTER.

Display Options menu appears. (“1 TV ASPECT” must be selected – highlighted.)

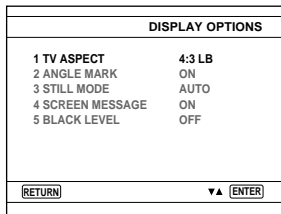

3 Press ENTER.

TV Aspect selecting screen appears.

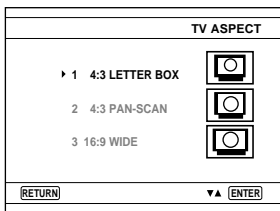

4 Press Cursor ▼ (or ▲) to select (highlight) a desired setting, then press ENTER.

To erase the Setup menu, press RETURN repeatedly until the Setup menu disappears.

- **1 4:3 LETTER BOX:** Select this when viewing on TV whose aspect ratio is 4:3. While viewing a wide screen picture, the black bars appear on the top and the bottom of the screen.

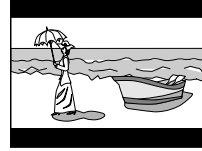

- **2 4:3 PAN-SCAN:** Select this when viewing on TV whose aspect ratio is 4:3. While viewing a wide screen picture, the black bars do not appear, however, the left and right edge sides of the pictures will not be shown on the screen.

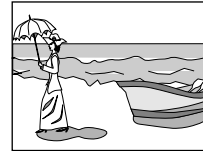

- **3 16:9 WIDE:** Select this when viewing on TV whose aspect ratio is 16:9.

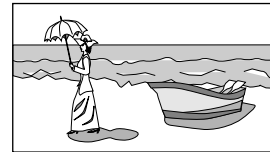

- **Even if “4:3 PAN-SCAN” is selected,** the screen size may become “4:3 LETTER BOX” while playing some DVDs. This depends on how the DVD is programmed and recorded.
- **If a disc (or some portions of the disc) is recorded with the video signals of 4:3 aspect ratio,** this setting does not take effect. The pictures are displayed with full 4:3 aspect ratio or with 4:3 Letter box.

Setting the Angle Mark

When playing a DVD containing multi-angle views, you can show the angle mark on the upper right corner of the TV screen.

To go back to the previous screen during the procedure, press RETURN.

1 Press SETUP.

Setup menu appears on the TV screen.

2 Press Cursor ▼ (or ▲) to select (highlight) “7 DISPLAY OPTIONS,” then press ENTER.

Display Options menu appears. (“1 TV ASPECT” must be selected – highlighted.)

3 Press Cursor ▼ (or ▲) to select (highlight) “2 ANGLE MARK,” then press ENTER.

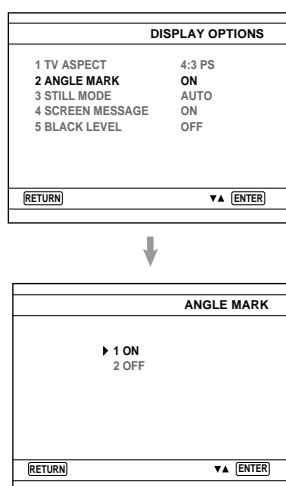

4 Press Cursor ▼ (or ▲) to select (highlight) a desired setting, then press ENTER.

- 1 ON: Select this to display the angle mark.
- 2 OFF: Select this not to display the angle mark.

To erase the Setup menu, press RETURN repeatedly until the Setup menu disappears.

Setting the Still Picture Quality

If the picture shakes or small letters cannot be shown clearly during still picture playback, set the still picture mode.

To go back to the previous screen during the procedure, press RETURN.

1 Press SETUP.

Setup menu appears on the TV screen.

2 Press Cursor ▼ (or ▲) to select (highlight) “7 DISPLAY OPTIONS,” then press ENTER.

Display Options menu appears. (“1 TV ASPECT” must be selected – highlighted.)

3 Press Cursor ▼ (or ▲) to select (highlight) “3 STILL MODE,” then press ENTER.

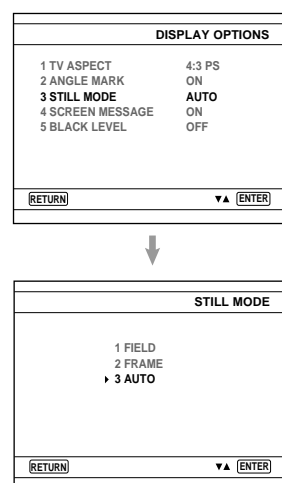

4 Press Cursor ▼ (or ▲) to select (highlight) a desired setting, then press ENTER.

- 1 FIELD: Select this if the picture shakes with “3 AUTO” selected.
- 2 FRAME: Select this if small letters cannot be clearly shown with “3 AUTO” selected.
- 3 AUTO: Normally select this.

To erase the Setup menu, press RETURN repeatedly until the Setup menu disappears.

Setting the Screen Messages

During disc operation, it is recommended to set this function to “ON” so that you can confirm what you are doing on the TV screen.

To go back to the previous screen during the procedure, press RETURN.

1 Press SETUP.

Setup menu appears on the TV screen.

2 Press Cursor ▼ (or ▲) to select (highlight) “7 DISPLAY OPTIONS,” then press ENTER.

Display Options menu appears. (“1 TV ASPECT” must be selected – highlighted.)

3 Press Cursor ▼ (or ▲) to select (highlight) “4 SCREEN MESSAGE,” then press ENTER.

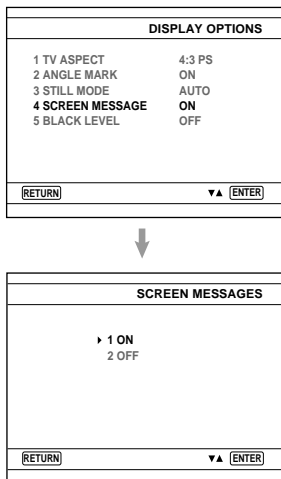

4 Press Cursor ▼ (or ▲) to select (highlight) a desired setting, then press ENTER.

- **1 ON:** Select this to show the on-screen indications on the TV screen.
- **2 OFF:** Select this not to show the on-screen indications.

To erase the Setup menu, press RETURN repeatedly until the Setup menu disappears.

Setting the Brightness

Using this function, you can change the brightness of the on-screen display.

To go back to the previous screen during the procedure, press RETURN.

1 Press SETUP.

Setup menu appears on the TV screen.

2 Press Cursor ▼ (or ▲) to select (highlight) “7 DISPLAY OPTIONS,” then press ENTER.

Display Options menu appears. (“1 TV ASPECT” must be selected – highlighted.)

3 Press Cursor ▼ (or ▲) to select (highlight) “5 BLACK LEVEL,” then press ENTER.

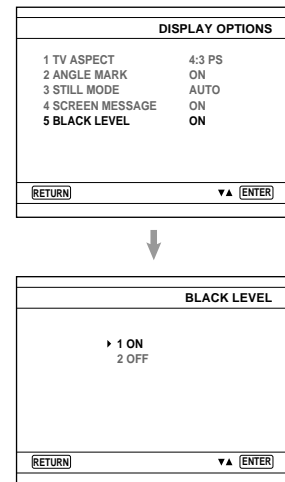

4 Press Cursor ▼ (or ▲) to select (highlight) a desired setting, then press ENTER.

- **1 ON:** Select this to darken the on-screen display.
- **2 OFF:** Select this to brighten the on-screen display.

To erase the Setup menu, press RETURN repeatedly until the Setup menu disappears.

Playing Back Tapes

Playing Back a Tape

- 1** Press EJECT (▲) for the deck you want to use.

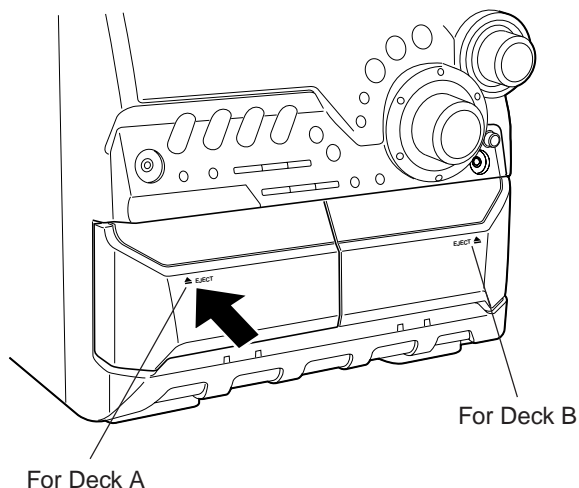

- 2** Put a cassette in with the exposed part of the tape down.

- You can play back only type I.

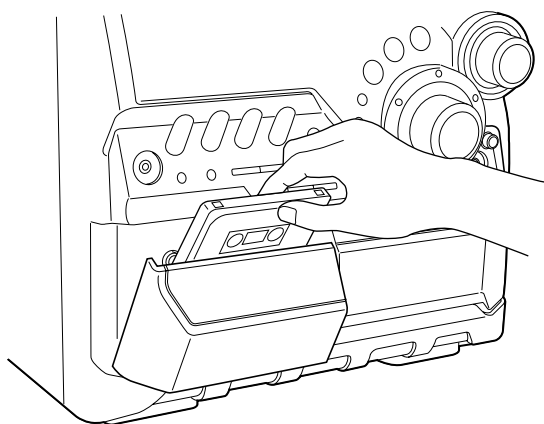

- 3** Close the cassette holder gently.

If you put cassettes in both decks A and B, the last deck which you have put a cassette into is selected.

To operate the other deck, press TAPE A or TAPE B (or TAPE A/B on the remote control).

- 4** Press TAPE ◀▶.

The tape play starts and the tape direction indicator (◀▶) starts flashing slowly to indicate the tape running direction.

- Each time you press the button, the tape direction changes.

- ▶: plays the front side.
- ◀: plays the reverse side.

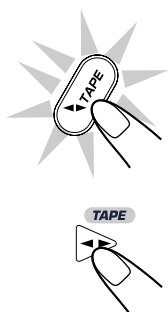

When the tape plays to the end, the deck automatically stops if the Reverse Mode is canceled. (See “To play both sides repeatedly — Reverse Mode.”)

To stop during play, press ■.

To operate the other deck, press TAPE A or TAPE B (or TAPE A/B on the remote control), then TAPE ◀▶.

To fast wind to the left or to the right, press ◀◀ / ▶▶ (◀◀ or ▶▶ on the remote control.)

The tape direction indicator (◀▶) starts flashing quickly on the display.

To remove the cassette, press ▲ EJECT for deck A or EJECT ▲ for deck B.

To play both sides repeatedly — Reverse Mode

Reverse Mode works for both decks at the same time.

When it is in use, the tape automatically reverses at the end of a side and the unit starts playing the other side of the tape, and repeats the same process.

To use Reverse Mode, press REVERSE MODE so that the Reverse Mode indicator on the display lights up like — (↔)

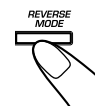

To cancel Reverse Mode, press the button again so that the Reverse Mode indicator on the display lights up like — → ←



notes When Reverse Mode is on with cassettes in both decks A and B

After the reverse (◀) side of the tape finishes playing, the tape in the other deck starts playing.



The use of the C-120 or thinner tape is not recommended, since characteristic deterioration may occur and this tape easily jams in the pinch-rollers and the capstans.

Recording

IMPORTANT:

- It may be unlawful to record or play back copyrighted material without the consent of the copyright owner.
- The recording level is automatically set correctly, so it is not affected by the VOLUME control, the SOUND MODE control, and the SUBWOOFER LEVEL control. Thus, during recording you can adjust the sound you are actually listening to without affecting the recording level.
- If recordings you have made have excessive noise or static, the unit may be too close to a TV. Place the unit away from the TV.
- You can use type I tape for recording.

To protect your recording

Cassettes have two small tabs on the back to protect unexpected erasure or re-recording.

To protect your recording, remove these tabs.

To re-record on a protected tape, cover the holes with adhesive tape.

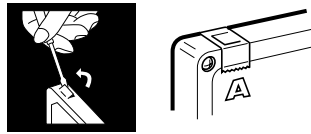

To keep the best recording and playback sound quality

If the heads, capstans, and pinch rollers of the cassette decks become dirty, the following will occur:

- Impaired sound quality
- Discontinuous sound
- Fading
- Incomplete erasure
- Difficulty in recording

To clean the heads, capstans, and pinch rollers

Use a cotton swab moistened with alcohol.

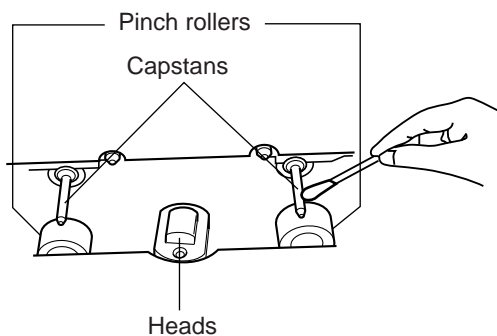

To demagnetize the heads

Turn off the unit, and use a head demagnetizer (available at electronics and audio shops).

Recording a Tape on Deck B

On the unit ONLY:

1 Press EJECT ▲ for the deck B.

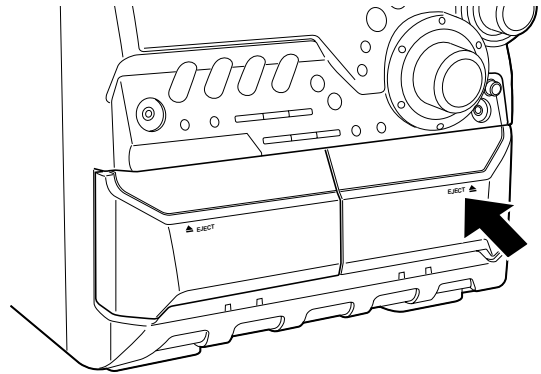

2 Put a recordable cassette in with the exposed part of the tape down.

3 Close the cassette holder gently.

4 Check the tape direction of deck B.

- If the tape direction is not correct, press TAPE ◀▶ twice then ■ to change the tape direction.

5 Start playing the source — FM, AM, DVD player or auxiliary equipment connected to AUX IN jacks.

- When you want to use the dubbing method, see “Dubbing Tapes” on page 38.
- When the source is CD, you can also use CD Synchro Recording (see “CD Synchronized Recording” on page 38.)

6 Press REC START/STOP.

The REC (recording) indicator lights up on the display and recording starts.



To stop during recording, press REC START/STOP again or ■.

To remove the cassette, press EJECT ▲ for deck B.

To record on both sides — Reverse Mode

Press REVERSE MODE so that the Reverse Mode indicator lights up as — (↔)

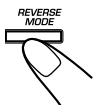

- When using the Reverse Mode for recording, start recording in the forward (▶) direction first. Otherwise, recording will stop when recording is done only on one side (reverse) of the tape.

To cancel Reverse Mode, press the button again so that the Reverse Mode indicator lights up as — → ←

Dubbing Tapes

On the unit ONLY:

1 Press TAPE ◀▶, then ■.

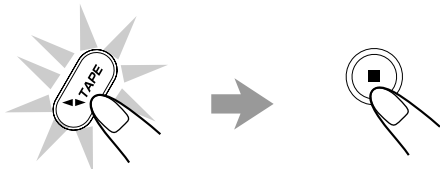

2 Put the source cassette in deck A, and a recordable cassette into deck B.

3 Press DUBBING.

Dubbing starts.
“DUBBING” appears, and the REC (recording) indicator lights up on the display.

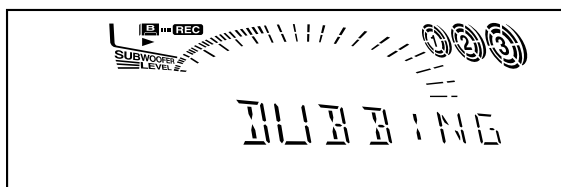

To stop during dubbing, press ■.

To remove the cassette, press ▲ EJECT for deck A and EJECT ▲ for deck B.

To record on both sides — Reverse Mode

Press REVERSE MODE so that the Reverse Mode indicator lights up as — (↔)



To cancel Reverse Mode, press the button again so that the Reverse Mode indicator lights up as — ↔

CD Synchronized Recording

You can easily record a disc onto a tape.

- You can also record the tracks in order you have made the program.

On the unit ONLY:

1 Put a recordable cassette into deck B.

2 Place a disc correctly on the circle of the disc tray, with its label side up.

3 Press one of the disc number buttons (DVD1, DVD2 or DVD3) to select the disc, then ■.

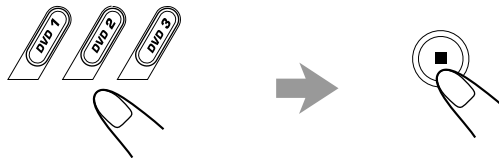

4 Press CD REC START.

“CD REC” appears, and the REC (recording) indicator lights up on the display.

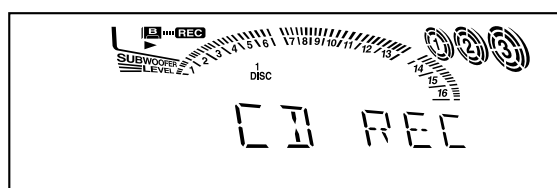
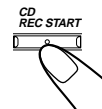

Deck B starts recording and the DVD player starts playing.

When the recording is done, the DVD player and deck B stop.

To stop during CD Synchronized Recording, press ■.

To remove the cassette, press EJECT ▲ for deck B.

To record on both sides — Reverse Mode

Press REVERSE MODE so that the Reverse Mode indicator lights up as — (↔)

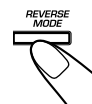

- When using the Reverse Mode for CD Synchronized Recording, start recording in the forward (▶) direction first. When the tape reaches its end while recording a song in the forward direction (▶), the last song will be recorded at the beginning of the reverse side (◀).
- If you start recording on the reverse side (◀), recording will stop when recording is done only on one side (reverse) of the tape.

To cancel Reverse Mode, press the button again so that the Reverse Mode indicator lights up as — ↔

Enjoying Karaoke Play

IMPORTANT:

- Always set the MIC LEVEL to MIN when connecting or disconnecting the microphone.
- When you do not use the microphone, keep the microphones unconnected.

Singing Along (Karaoke) — Basic Procedure

1 Rotate MIC LEVEL to MIN.

2 Connect the microphone (not supplied) by plugging it into the MIC jack.

The karaoke indicator () lights up on the display.



3 Prepare the source, select an appropriate Karaoke mode, then start playback.

- To enjoy Karaoke play using multiplex Karaoke discs such as CD-G, VCD, and DVD, see “Singing Along Using Multiplex Karaoke Discs” that follows.
- To enjoy Karaoke play using multiplex tapes, see “Singing Along Using Multiplex Tapes — Multiplex Sound (MPX)” on page 41.
- To enjoy Karaoke play using stereo sources such as stereo CD or tapes, see “Singing Along Using the Conventional Stereo sources — Vocal Masking” on page 41.

4 Rotate MIC LEVEL and VOLUME controls as you sing into the microphone.

- By pressing REC START/STOP, you can record your singing along if you want. (For more details, see page 37.)

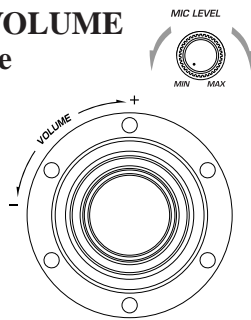

To apply an echo to your voice

Press ECHO on the remote control so that the echo indicator () lights up on the display.

Each time you press the button, the echo level changes as follows:

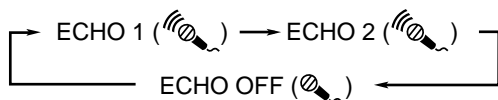

As the number increases, a stronger echo effect applies to your voice.

- This function is available only while connecting a microphone.



When you finish enjoying Karaoke

DO NOT forget to cancel the Karaoke mode you used; otherwise, normal playback will not be possible.

Singing Along Using Multiplex Karaoke Discs

While playing a multiplex Karaoke disc — CD-G, VCD, and DVD, you can use the following functions.

- Request
- Vocal Fader
- Melody Guide (only possible on DVDs containing Melody Guide function)
- Key Control

Request (Karaoke Program Play)



You can determine the playback order of the songs (titles or tracks) you want.

On the remote control ONLY:

1 Load a disc.

- If the current playing source is not the DVD player, press DVD1, DVD2 or DVD3 on the unit to select the disc you want to play, then  before going to the next step.

2 Press KARAOKE to turn on Karaoke mode.

Be sure to turn on the Karaoke mode by pressing Cursor  (or ) before going to step 3.

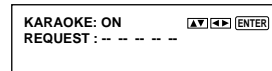

3 Press Cursor (or) to enter Request mode.

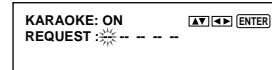

4 Select title or track numbers you want

- To select number 5, press 0, 5 (or simply press 5.)
- To select number 10, press 1, 0.
- To select number 23, press 2, 3.

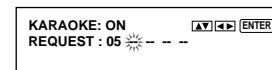
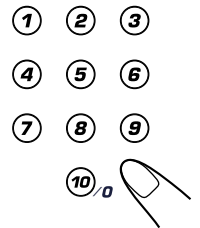

5 Start playing the multiplex disc.



When you finish enjoying Karaoke

DO NOT forget to cancel the Karaoke mode you used; otherwise, normal playback will not be possible.

■ Vocal Fader

By using Vocal Fader, you can mute the vocal part of a multiplex Karaoke disc during playback.

- See also “Singing Along Using Multiplex Tapes — Multiplex Sound (MPX)” on page 41.

On the remote control ONLY:

1 Press KARAOKE to turn on Karaoke mode during play.

Be sure to turn on the Karaoke mode by pressing Cursor ◀ (or ▶) before going to step 2.

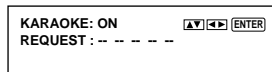

2 Press MODE repeatedly to show the Vocal Fader/Guide Melody screen on the TV.

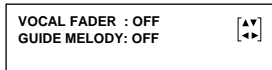

- Each time you press the button, Karaoke mode changes and the following screen appears:

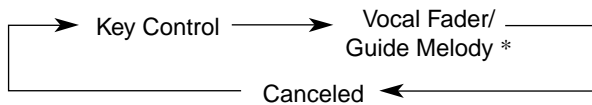

- * “GUIDE MELODY” will not appear while playing back a CD-G or VCD.

3 Press Cursor ▶ (or ◀) to select the appropriate Vocal Fader setting.

Each time you press the button, Vocal Fader changes as follows:

While playing a DVD:

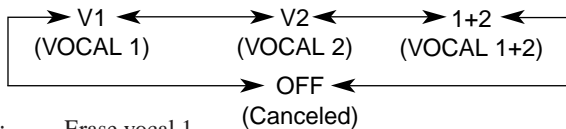

- V1: Erase vocal 1.
- V2: Erase vocal 2.
- 1+2: Erase vocal 1 and vocal 2.
- OFF: Cancels Vocal Fader.

While playing a CD-G or VCD:



- L: Erase the left channel signals.
- R: Erase the right channel signals.
- OFF: Cancels Vocal Fader.



When you finish enjoying Karaoke

Cancel the Karaoke mode; otherwise, normal playback will not be possible.

■ Guide Melody

By using Guide Melody signal contained on some DVD discs, you can follow the guide melody while singing.

- This function can only be used on a DVD containing Guide Melody signal.

On the remote control ONLY:

1 Press KARAOKE to turn on Karaoke mode during play.

Be sure to turn on the Karaoke mode by pressing Cursor ◀ (or ▶) before going to step 2.

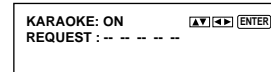

2 Press MODE repeatedly to show the Vocal Fader/Guide Melody screen on the TV.

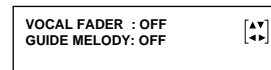

- Each time you press the button, Karaoke mode changes and the following screen appears:

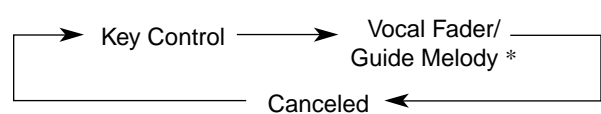

- * “GUIDE MELODY” will not appear while playing back a CD-G or VCD.

3 Press Cursor ▼ (or ▲) to select (highlight) Melody Guide.



4 Press Cursor ▶ (or ◀) to turn on Melody Guide.

Each time you press the button, Melody Guide turns on and off alternately.

- ON: You can use Melody Guide while singing.
- OFF: Cancels Melody Guide.

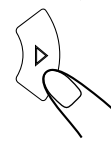

When you finish enjoying Karaoke

Cancel the Karaoke mode; otherwise, normal playback will not be possible.

■ Key Control

You can adjust the key of the source if it's not suit to your key.

- This function is available only of a multiplex Karaoke disc — CD-G, VCD, and DVD.

On the remote control ONLY:

1 Press KARAOKE to turn on Karaoke mode during play.

Be sure to turn on the Karaoke mode by pressing Cursor ◀ (or ▶) before going to step 2.

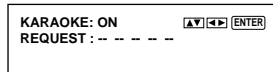

2 Press MODE repeatedly to show the Key Control screen on the TV.

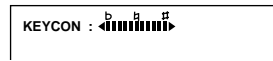

- Each time you press the button, Karaoke mode changes and the following screen appears:

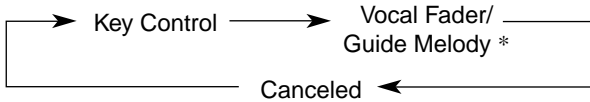

- * "GUIDE MELODY" will not appear while playing back a CD-G or VCD.

3 Press Cursor ▶ or ◀ to adjust the key.

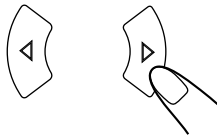

If you have adjusted the key

The key position remains unless you change it again. To restore the original key for the next song, reset the key control manually to "□ (natural)."



When you finish enjoying Karaoke

Cancel the Karaoke mode; otherwise, normal playback will not be possible.

Singing Along Using Multiplex Tapes — Multiplex Sound (MPX)

In a multiplex karaoke tape, the instrumental part is recorded on the left channel and the vocal part is recorded on the right channel. By using Multiplex Sound (MPX) function, you can select the channel to play back.

- This function can be also used for multiplex Karaoke discs.

On the remote control ONLY:

1 Press AUDIO/MPX during play.



2 Press Cursor ▼ (or ▲) to select the output sound.



- Each time you press the button, output sound changes as follows:

- LEFT: Only the left channel (instrumental parts) is played back through both the right and left speakers.
- RIGHT: Only the right channel (vocal parts) is played back through both the right and left speakers.
- STEREO: Cancels the Multiplex Sound (MPX) (normal stereo playback resumes).

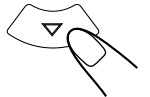

When you finish enjoying Karaoke

Cancel the Multiplex Sound (MPX) function; otherwise, normal playback will not be possible.

Singing Along Using the Conventional Stereo Sources — Vocal Masking

You can enjoy singing along (Karaoke) using Vocal Masking. Vocal Masking reduces the lead vocal of the playing source while playing back a source.

On the remote control ONLY:

Press VOCAL MASKING repeatedly.

Each time you press the button, Vocal Masking turns on (V.MASK) and off (OFF).



- V.MASK: Reduces the vocals.
- OFF: Cancels Vocal Masking (normal stereo playback resumes).



If you use the following sources as the playing source for Vocal Masking, you cannot get the satisfactory results

- Radio programs — a radio signal is not as reliable as the signals coming from a tape or disc.
- Monaural sources.
- Poorly dubbed tapes.
- Sources recorded with duets, strong echo, a chorus, or only a few instruments.



When you finish enjoying Karaoke

Cancel Vocal Masking; otherwise, normal playback will not be possible.

There are three timers available — Daily Timer, Recording Timer, and Sleep Timer.

Before using the timers, you need to set the clock built in the unit. (See “Setting the Clock” on page 10.)

Using Daily Timer

With Daily Timer, you can wake to your favorite music or radio program. You can set the timer whether the unit is on or off.

How Daily Timer actually works

The unit automatically turns on, set the volume level to the preset level, and starts playing the specified source when the on-time comes (the ☺ indicator flashes while the timer is operating). Then, when the off-time comes, the unit automatically turns off (stands by).

The timer setting remains in memory until you change it.

- There is a time limit in doing the following steps. If the setting is canceled before you finish, start from step 1 again.
- If you have made a mistake while setting timer, press CANCEL. (However, this does not always work. If CANCEL does not work, press CLOCK/TIMER repeatedly and start from step 1 again.)

Before you start...

- *When using a CD as the source to play* —
– Make sure there is a CD on the currently selected disc number tray.
- *When using a tape as the source to play* —
– Make sure that a tape is in the deck whose deck indicator (A or B) is lit on the display.
- *When using the external component as the source to play* —
– Set the timer equipped with the external component at the same time.

On the unit ONLY:

1 Press CLOCK/TIMER repeatedly until “DAILY” appears on the display.

The ☺ indicator lights up and the DAILY (daily timer) indicator also starts flashing on the display.

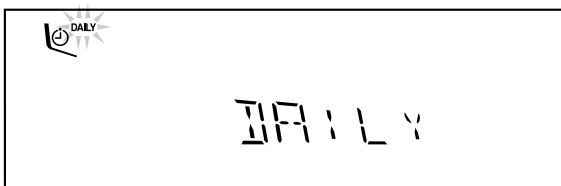

- Each time you press the button, the timer setting modes change as follows:

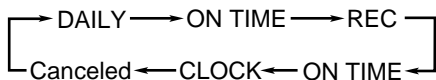

(See page 10.)

2 Press CLOCK/TIMER again.

“ON TIME” appears for 2 seconds, then the unit enters on-time setting mode.



3 Set the on-time you want the unit to turn on.

- 1) Press ◀◀ or ▶▶ to set the hour, then press SET.
 - 2) Press ◀◀ or ▶▶ to set the minute, then press SET.
- “OFF TIME” appears for 2 seconds, then the unit enters off-time setting mode.

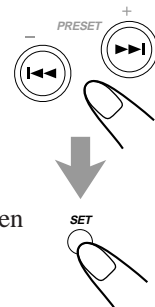

4 Set the off-time you want the unit to turn off (on standby).

- 1) Press ◀◀ or ▶▶ to set the hour, then press SET.
 - 2) Press ◀◀ or ▶▶ to set the minute, then press SET.
- The unit enters source selecting mode.

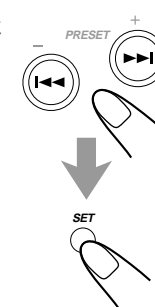

5 Press ◀◀ or ▶▶ to select the source to play, then press SET.

- Each time you press ◀◀ or ▶▶, the source changes as follows:

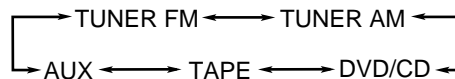

TUNER FM: tunes into a specified preset FM station.

→ go to step 6.

TUNER AM: tunes into a specified preset AM station.

→ go to step 6.

DVD/CD: plays a disc. → go to step 7.

TAPE: plays a tape in deck A or B. → go to step 7.

AUX: plays an external source. → go to step 7.

6 When you have selected “TUNER FM” or “TUNER AM” in step 5.

Select a preset station number.

Press ◀◀ or ▶▶ to select the preset station number, then press SET.

The unit enters volume setting mode.

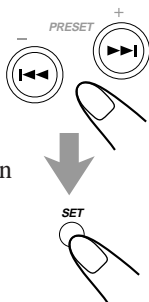

7 Press ◀◀ or ▶▶ to set the volume level.

- You can select the volume level from VOL MIN, VOL 1 — VOL 30, and VOL MAX.

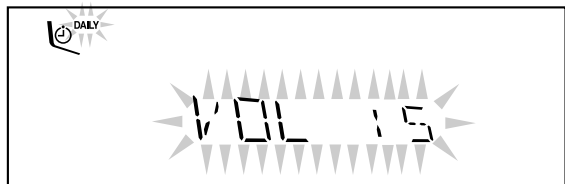
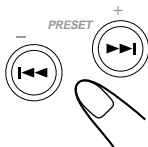

8 Press SET to complete the Daily Timer setting.

The DAILY (daily timer) indicator stops flashing and remains lit. The settings you have done are shown on the display in sequence for your confirmation.

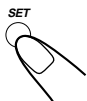

9 Press ⏻/STANDBY/ON to turn off the unit (on standby) if you have set the Daily Timer with the unit turned on.

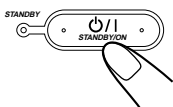

If the unit is turned on when the timer-on time comes Daily Timer does not work.

To turn on or off Daily Timer after its setting is done

1 Press CLOCK/TIMER repeatedly until “DAILY” appears on the display.



2 To turn off the Daily Timer, press CANCEL.

The DAILY (daily timer) indicator goes off from the display (“OFF” appears for a while). The Daily Timer is canceled, but the setting for the Daily Timer remains in memory.



To turn on the Daily Timer, press SET.

The DAILY (daily timer) indicator lights up on the display. The settings you have done are shown on the display in sequence for your confirmation.

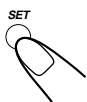

Using Recording Timer

With Recording Timer, you can make a tape of a radio broadcast automatically. You can set the timer whether the unit is on or off.

How Recording Timer actually works

The unit automatically turns on, tunes into the specified station, sets the volume level to “VOL MIN,” and starts recording when the on-time comes (the Ⓞ indicator flashes while the timer is operating). Then, when the off-time comes, the unit automatically turns off (stands by).

The timer setting remains in memory until you change it.

- There is a time limit in doing the following steps. If the setting is canceled before you finish, start from step 1 again.
- If you have made a mistake while setting the timer, press CANCEL. (However, this does not always work. If CANCEL does not work, press CLOCK/TIMER repeatedly and start from step 1 again.)

On the unit ONLY:

1 Put a recordable cassette into deck B.

2 Press CLOCK/TIMER repeatedly until “REC” appears on the display.

Ⓞ indicator lights up and the REC (recording timer) indicator also starts flashing on the display.



- Each time you press the button, the timer setting modes change as follows:

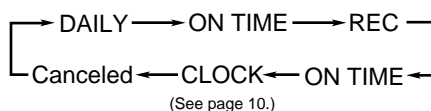

3 Press CLOCK/TIMER again.

“ON TIME” appears for 2 seconds, then the unit enters on-time setting mode.



4 Set the on-time you want the unit to turn on.

- 1) Press ◀◀ or ▶▶ to set the hour, then press SET.
- 2) Press ◀◀ or ▶▶ to set the minute, then press SET.
“OFF TIME” appears for 2 seconds, then the unit enters off-time setting mode.

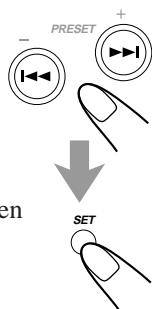

5 Set the off-time you want the unit to turn off (on standby).

- 1) Press ◀◀ or ▶▶ to set the hour, then press SET.
- 2) Press ◀◀ or ▶▶ to set the minute, then press SET.
The unit enters preset station selecting mode.

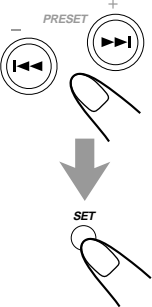

6 Select a preset station.

- 1) Press ◀◀ or ▶▶ to select the band (“TUNER FM” or “TUNER AM”), then press SET.
- 2) Press ◀◀ or ▶▶ to select a preset channel number, then press SET.
The REC (recording timer) indicator stops flashing and remains lit. The settings you have done are shown on the display in sequence for your confirmation.

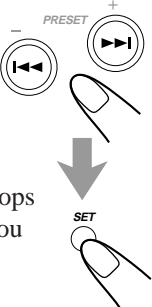

7 Press ⏻/STANDBY/ON to turn off the unit (on standby) if necessary.

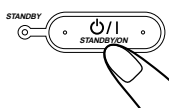

If you want to listen to another source while recording Press REC START/STOP or ■ to stop recording. Without stopping it, you cannot change the source.

To turn on or off Recording Timer after its setting is done

- 1 Press CLOCK/TIMER repeatedly until “REC” appears on the display.



- 2 To turn off the Recording Timer, press CANCEL.

The REC (recording timer) indicator goes off from the display (“OFF” appears for a while). The Recording Timer is canceled, but the setting for the Recording Timer remains in memory.

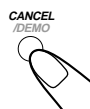

To turn on the Recording Timer, press SET.

The REC (recording timer) indicator lights up on the display. The settings you have done are shown on the display in sequence for your confirmation.

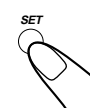

Using Sleep Timer

With Sleep Timer, you can fall asleep to music. You can set Sleep Timer when the unit is turned on.

How Sleep Timer actually works

The unit automatically turns off after the specified time length passes.

On the remote control ONLY:

1 Press SLEEP.

The time length until the shut-off time appears and the SLEEP indicator starts flashing on the display.

- Each time you press the button, the time length changes as follows:

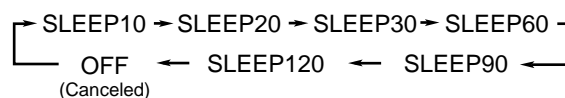

2 Wait for about 5 seconds after specifying the time length.

The SLEEP indicator stops flashing and remains lit.

To check the remaining time until the shut-off time, press SLEEP once so that the remaining time until the shut-off time appears for about 5 seconds.

To change the shut-off time, press SLEEP repeatedly until the desired time length appears on the display.

To cancel the setting, press SLEEP repeatedly until “OFF” appears on the display so that the SLEEP indicator goes off from the display.

- Sleep Timer is also canceled when you turn off the unit.

Timer Priority

Since each timer can be set separately, you may wonder what happens if the setting for these timers overlaps. Here are examples.

- **Recording Timer has priority over Daily Timer.**

If Daily Timer is set to come on while Recording Timer is operating, Daily Timer will not come on at all.

- If Sleep Timer overlaps with another timer (either Daily Timer or Recording Timer), a timer with the earlier shut-off time has priority.

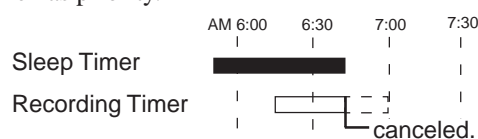

When using the Recording Timer and Sleep Timer at the same time, pay special attention to the shut-off time.

Maintenance

To get the best performance of the unit, keep your discs, tapes, and mechanism clean.

Handling discs



- Remove the disc from its case by holding it at the edge while pressing the center hole lightly.
- Do not touch the shiny surface of the disc, or bend the disc.
- Put the disc back in its case after use to prevent warping.

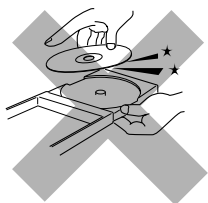

- Be careful not to scratch the surface of the disc when placing it back in its case.
- Avoid exposure to direct sunlight, temperature extremes, and moisture.



To clean the disc

Wipe the disc with a soft cloth in a straight line from center to edge.



DO NOT use any solvent — such as conventional record cleaner, spray, thinner, or benzine — to clean the disc.

Handling cassette tapes

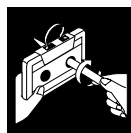

- If the tape is loose in its cassette, take up the slack by inserting a pencil in one of the reels and rotating.
- If the tape is loose, it may get stretched, cut, or caught in the cassette.



- Be careful not to touch the tape surface.



- Avoid the following places to store the tape:
 - In dusty places
 - In direct sunlight or heat
 - In moist areas
 - Near a magnet

Glossary

Dolby Digital

This is a digital audio compression format that was developed by Dolby Laboratories. Dolby Digital encoding method (so-called discrete 5.1 channel digital audio format) records and compresses the left front channel, right front channel, center channel, left rear channel, right rear channel, and LFE channel (total 6 channels, but LFE channel is counted as 0.1 channel, therefore called 5.1 channels) signals digitally. Each channel is completely independent from other channel signals to avoid interference, therefore, you can obtain much better sound quality with stereo and surround effects.

To reproduce these original surround signals, you need to connect an amplifier or a decoder compatible with Dolby Digital.

DTS Digital Surround

Another discrete 5.1 channel digital audio format, available on CD, LD, and DVD software, developed by Digital Theater Systems, Inc.

Compared to Dolby Digital, audio compression rate is relatively low. This fact allows DTS Digital Surround format to add breadth and depth to the reproduced sounds. As a result, DTS Digital Surround features natural, solid and clear sound.

To reproduce these surround signals, you need to connect an amplifier or a decoder compatible with DTS Digital Surround.

Linear PCM

This is a digital recording format that is used for audio CDs.

MPEG Audio/MPEG Multichannel

Digital audio compression format used for PAL/SECAM DVD software. (MPEG stands for “Moving Picture Experts Group” and has been originally developed for compressing video signals.)

MPEG Multichannel is 5.1 channel surround using MPEG Audio coding format.

Playback Control (PBC)

When a VCD has the PBC (Playback Control) function, you can enjoy menu-driven operations and high-resolution still pictures.

Sampling Frequency, Quantization Bits

When analog signals are converted into digital signals, they are divided into many points and digitized. This dividing method is called “sampling.” The sampling frequency indicates how many points one second is divided into – for example, for CD sound, one second is divided into 44100 points since its sampling frequency is 44.1 kHz. On the other hand, the number of quantization bits indicates the volume size used to memorize each divided point.

The larger this number is, the clearer the sound can be reproduced.

Troubleshooting

If you are having a problem with your unit, check this list for a possible solution before calling for service.

If you cannot solve the problem from the hints given here, or the unit has been physically damaged, call a qualified person, such as your dealer, for service.

Symptom	Cause	Action
Unable to cancel the display demonstration.	Other buttons are pressed to cancel the display demonstraton.	Press DEMO on the unit. (See page 9.)
No sound is heard.	<ul style="list-style-type: none"> • Connections are incorrect or loose. • You are playing a disc with DTS Digital Surround. 	<ul style="list-style-type: none"> • Check all connections and make corrections. (See pages 6 to 9.) • This unit cannot output DTS sound without connecting a decoder compatible with DTS Digital Surround (with “DTS” to “ON” — See page 31.)
Hard to listen to broadcasts because of noise.	<ul style="list-style-type: none"> • Antennas are disconnected. • The AM loop antenna is too close to the unit. • The FM antenna is not properly extended and positioned. 	<ul style="list-style-type: none"> • Reconnect the antennas correctly and securely. • Change the position and direction of the AM loop antenna. • Extend the FM antenna at the best position.
The disc sound is discontinuous.	The disc is scratched or dirty.	Clean or replace the disc. (See page 45.)
The carrousel does not open or close.	<ul style="list-style-type: none"> • The AC power cord is not plugged in. • The carrousel is locked. 	<ul style="list-style-type: none"> • Plug the AC power cord. • Unlock the carrousel. (See page 18.)
The disc does not play.	The disc is placed upside down.	Place the disc with the label side up.
No picture appears on the screen.	<ul style="list-style-type: none"> • The video cord is not connected correctly. • An incorrect input has been selected on the TV or monitor. 	<ul style="list-style-type: none"> • Connect the video cord correctly. • Select the correct input on the TV or monitor.
The left and right edges of the picture are missing on the screen.	“4:3 PAN-SCAN (PS)” is selected when viewing on a conventional TV (aspect ratio 4:3).	Select “4:3 LETTER BOX (LB).” (See page 33.)
No subtitle appears on the display though you have selected the initial subtitle language.	_____	Some DVDs are programed to always display no subtitle initially. If this happens, press SUBTITLE on the remote control after starting play.
Audio language is different from the one you have selected as the initial audio language.	_____	Some DVDs are programed to always use the original language initially. If this happens, press AUDIO/MPX on the remote control after starting play.
The cassette holders cannot be opened.	Power supply from the AC power cord has been cut off while the tape was running.	Turn on the unit.
Impossible to record.	Small tabs on the back of the cassette are removed.	Cover the holes with adhesive tape.
Operations are disabled.	The built-in microprocessor may malfunction due to external electrical interference.	Unplug the AC power cord and then plug it back in.
Unable to operate the unit from the remote control.	<ul style="list-style-type: none"> • The path between the remote control and the remote sensor on the unit is blocked. • The batteries are exhausted. 	<ul style="list-style-type: none"> • Remove the obstruction. • Replace the batteries.

Amplifier section — CA-MXDVA5

Output Power

SUBWOOFERS: 70 W per channel, min. RMS, driven into 6 Ω at 63 Hz with no more than 10% total harmonic distortion.

MAIN SPEAKERS: 30 W per channel, min. RMS, driven into 4 Ω at 1 kHz with no more than 10% total harmonic distortion.

Audio input sensitivity/Impedance

(at 1 kHz, measured at MAIN SPEAKERS)

AUX IN: 400 mV/50 kΩ

MIC: 2.5 mV/5 kΩ

Audio output level/Impedance

LINE OUT: 400 mV/4.7 kΩ

Digital output: DIGITAL OUT (OPTICAL)

Signal wave length: 660 nm

Output level: -21 dBm to -15 dBm

Speakers/Impedance: Subwoofer: 6 Ω — 16 Ω

Main speaker: 4 Ω — 8 Ω

Tuner

FM tuning range: 87.50 MHz — 108.00 MHz

AM tuning range: At 9 kHz intervals: 531 kHz — 1 602 kHz

At 10 kHz intervals: 530 kHz — 1 710 kHz

DVD player

Disc Capacity: 3 discs

Frequency response

DVD, fs=48 kHz : 16 Hz to 22 000 Hz

DVD, fs=96 kHz : 16 Hz to 44 000 Hz

CD, VCD: 16 Hz to 20 000 Hz

Dynamic range: 85 dB

Signal-to-noise ratio: 85 dB

Cassette deck

Frequency response

Normal (type I): 50 Hz — 14 000 Hz

Wow and flutter

0.15% (WRMS)

General

Power requirement: AC 110 V/127 V/220 V/230V — 240 V[~],
adjustable with the voltage selector,
50 Hz/60 Hz

Power consumption: 180 W (at operation)
17 W (on standby)

Dimensions (approx.): 270 mm x 317 mm x 447 mm (W/H/D)
(10^{11/16} in. x 12^{1/2} in. x 17^{5/8} in.)

Mass (approx.): 9.9 kg (21.9 lbs)

Supplied accessories

See page 6.

Design and specifications are subject to change without notice.

Mains (AC) Line Instruction (not applicable for Europe, U.S.A., Canada, Australia, and U.K.)

تعليمات خط التيار الكهربائي الرئيسي (المتردد) (لا تنطبق على أوروبا والولايات المتحدة الأمريكية وكندا وأستراليا والمملكة المتحدة)

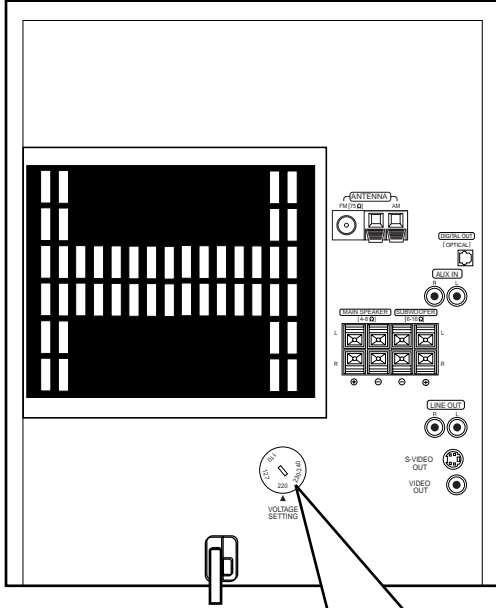

IMPORTANT for mains (AC) line

BEFORE PLUGGING IN, do check that your mains (AC) line voltage corresponds with the position of the voltage selector provided on the outside of this equipment and, if different, reset the voltage selector switch, to prevent from a damage or risk of fire/electric shock.

هام من اجل خط التيار الكهربائي الرئيسي (المتردد) قبل ادخال قابس الطاقة الكهربائية، تأكد من تطابق منتخب فولطية التيار الكهربائي الرئيسي (المتردد) الموجود على خلفية الجهاز مع فولطية التيار الكهربائي في بلدك. في حالة عدم التطابق، اعد ضبط مفتاح منتخب الفولطية على فولطية التيار الكهربائي المتردد في بلدك. عدم عمل ذلك، يمكن يؤدي الى حصول ضرر او حريق او صدمة كهربائية.

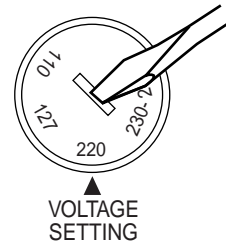

JVC INSTRUCTIONS

SPEAKER SYSTEM SP-MXDVA5

MANUAL DE INSTRUCCIONES: SISTEMA DE ALTAVOCES

INSTRUÇÕES: SISTEMA DE ALTIFALANTES

说明书: 扬声器系统

دليل التعليمات: لنظام السماعات

Thank you for purchasing JVC speakers.

Before you begin using them, please read the instructions carefully to be sure you get the best possible performance. If you have any questions, consult your JVC dealer.

Le estamos muy agradecidos por haber adquirido estos altavoces de JVC. Antes de utilizarlos, sírvase leer las instrucciones detenidamente a fin de obtener el mejor rendimiento posible. Si tienenaluna pregunta, acuda a su agente de JVC.

Gratos pela aquisição dos altifalantes JVC.

Antes de desfrutar este sistema, leia atentamente as instruções que o acompanham, de modo a assegurar-se da obtenção do melhor desempenho possível. Caso surjam dúvidas concernentes a este sistema, consulte o seu agente JVC.

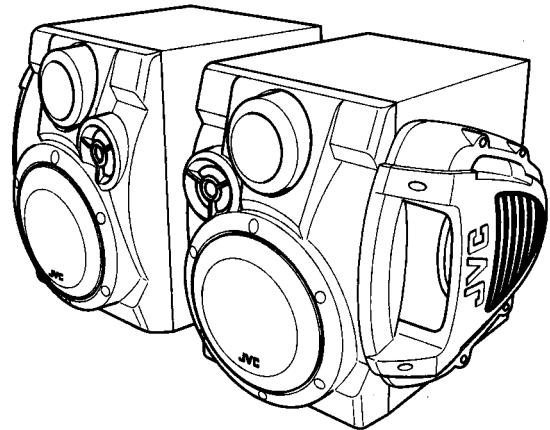

感谢您惠购 JVC 扬声器。

在开始使用之前，请您仔细阅读本使用说明书，以确保您获得扬声器的最佳性能。如有疑问，请与 JVC 代理销售商联系。

نشكرك على شراء سماعات جي في سي JVC.

قبل أن تبدأ استعمالها، يرجى قراءة هذه التعليمات بعناية حتى تتأكد من حصولك على أفضل أداء. إذا كان عندك أية أسئلة، عندها راجع موزع JVC لديك.

— SAFETY INSTRUCTIONS —

“SOME DOS AND DON'TS ON THE SAFE USE OF EQUIPMENT”

This equipment has been designed and manufactured to meet international safety standards but, like any electrical equipment, care must be taken if you are to obtain the best results and safety is to be assured.

Do read the operating instructions before you attempt to use the equipment.

Do ensure that all electrical connections (including the mains plug, extension leads and interconnections between pieces of equipment) are properly made and in accordance with the manufacturer's instructions. Switch off and withdraw the mains plug when making or changing connections.

Do consult your dealer if you are ever in doubt about the installation, operation or safety of your equipment.

Do be careful with glass panels or doors on equipment.

DON'T continue to operate the equipment if you are in any doubt about it working normally, or if it is damaged in any way — switch off, withdraw the mains plug and consult your dealer.

DON'T remove any fixed cover as this may expose dangerous voltages.

DON'T leave equipment switched on when it is unattended unless it is specifically stated that it is designed for unattended operation or has a standby mode.

Switch off using the switch on the equipment and make sure that your family know how to do this.

Special arrangements may need to be made for infirm or handicapped people.

DON'T use equipment such as personal stereos or radios so that you are distracted from the requirements of traffic safety. It is illegal to watch television whilst driving.

DON'T listen to headphones at high volume as such use can permanently damage your hearing.

DON'T obstruct the ventilation of the equipment, for example with curtains or soft furnishing.

Overheating will cause damage and shorten the life of the equipment.

DON'T use makeshift stands and NEVER fix legs with wood screws — to ensure complete safety always fit the manufacturer's approved stand or legs with the fixings provided according to the instructions.

DON'T allow electrical equipment to be exposed to rain or moisture.

ABOVE ALL

- NEVER let anyone, especially children, push anything into holes, slots or any other opening in the case.
- this could result in a fatal electrical shock;
- NEVER guess or take chances with electrical equipment of any kind
- it is better to be safe than sorry!

SPEAKER FOR A/V COMBINATION

SP-MXDVA5 have a magnetically-shielded design for placement adjacent to TV's and monitors without causing color aberrations. However, color may be affected as a result of how the speaker system is installed. Therefore, be careful of the following:

1. When placing these speakers near a TV set, turn off the TV's main power switch or unplug it before installing the speakers. Wait at least 30 minutes after the system is installed before turning on the TV's power.
2. If another speaker system has been set up near the TV set, that system may cause color unevenness in the TV's picture.
3. In spite of the shielded design of these speakers, some types of TV's may be affected by them. If this happens, move the speakers a short distance from the TV set.

ALTAVOZ PARA COMBINACIÓN A/V

El modelo SP-MXDVA5 tiene una construcción protegida magnéticamente para una colocación contigua de los televisores y monitores sin causar aberraciones de color.

Sin embargo, el color puede ser afectado como resultado del modo de instalar el sistema de altavoces.

1. Al colocar los altavoces cerca de un televisor, desactivar el interruptor de alimentación principal del televisor o desconectarlo antes de instalar los altavoces. Esperar a lo menos 30 minutos después de instalar el sistema y antes de activar la alimentación del televisor.
2. Si otro sistema del altavoz ha sido ajustado cerca del televisor, este sistema puede causar una desigualdad de color en la imagen del televisor.
3. A pesar de la protección de estos altavoces, algunos tipos del televisores pueden estar afectados por ellos. En este caso, mover los altavoces a una distancia corta de la unidad del televisor.

ALTIFALANTES PARA COMBINAÇÃO A/V

O SP-MXDVA5 tem uma estrutura blindada magneticamente para sua colocação perto de televisores e monitores sem causar anormalidades nas cores.

No entanto, as cores podem ser afectadas, dependendo de como o sistema de altifalantes for instalado. Tenha portanto cuidado com os seguintes pontos:

1. Ao colocar estes altifalantes perto de um televisor, desligue o interruptor de alimentação principal do televisor ou desligue-o da rede eléctrica antes de instalar os altifalantes. Espere pelo menos 30 minutos após a instalação do sistema antes de voltar a ligar o televisor.
2. Se houver um outro sistema de altifalantes instalado perto do televisor, tal sistema poderá causar irregularidade nas cores da imagem do televisor.
3. Apesar da estrutura blindada destes altifalantes, alguns tipos de televisores podem ser afectados por eles. Se isso acontecer, afaste os altifalantes um pouco do televisor.

A/V 组合扬声器

SP-MXDVA5 具有防磁设计，使之可邻置于电视机和监视器旁而不会引起荧光屏色彩失常。然而，色彩将因扬声器系统的安装程序而受影响，因此请注意下列事项：

1. 当靠近电视机安置这些扬声器时，在安装之前先关断电视机的主电源开关或拔出电源插头。在整个系统被安装好后，至少要等 30 分钟后才可打开电视机的电源。
2. 如果其他的扬声器系统已被置于电视机旁，则那个系统可能会引起电视机图象的色彩不均匀。
3. 尽管这些扬声器系统具有防磁设计，但有些电视机仍会受其影响。如果发生此现象，请将扬声器系统移得离电视机稍微远一些。

سماعة من أجل مجموعة الصوت A/V

تحتوي الوحدة SP-MXDVA5 على تصميم ذو حائل مغناطيسي من أجل الوضع بجوار أجهزة التلفزيون وأجهزة المراقبة بدون التسبب في انحراف الالوان. لكن قد تتأثر الالوان نتيجة طريقة تركيب نظام السماعة. لذلك، إحرص على التالي:

- ١- عند وضع تلك السماعات بجوار جهاز تلفزيون، إفصل مفتاح القدرة الرئيسي بجهاز التلفزيون أو إفصل قابسه قبل تركيب السماعات. إنتظر ٣٠ دقيقة على الأقل بعد تركيب النظام وقبل وصل قدرة جهاز التلفزيون. ٢- إذا كان هناك نظام سماعة آخر موضوع بجوار جهاز التلفزيون، فقد يتسبب ذلك النظام في عدم انتظام الالوان في صورة جهاز التلفزيون. ٣- على الرغم من التصميم ذو الحائل لتلك السماعات، فقد تتأثر بعض أنواع أجهزة التلفزيون بواسطتهم. إذا حدث ذلك، قم بتحريك السماعات مسافة قصيرة عن جهاز التلفزيون.

Connection

Conexión

Ligação

接线

التوصيل

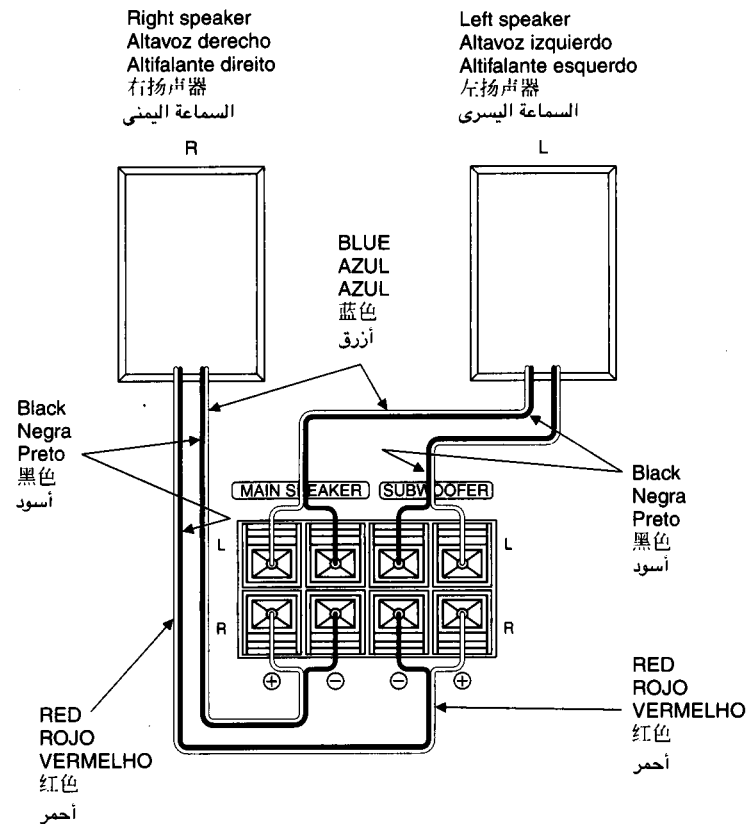

Amplifier output terminals
Terminales de salida de amplificador
Terminais de saída do amplificador
放大器输出端子
نهايات خرج المضخم

CONNECTION

- DO NOT use other amplifier to operate this speaker system except for CA-MXDVA5.
- Turn off power to the whole system before connecting the speakers to the amplifier.
- The maximum power handling capacity of the SP-MXDVA5 main speaker is 40 W Subwoofer is 80 W. Excessive input will result in abnormal noise and possible damage. In cases where the signals described below are applied to the speakers, even if the signals are below the maximum allowable input, they may cause an overload and burn the wiring of the speakers. Be sure to lower the amplifier volume beforehand.
 - 1) Noise during FM tuning.
 - 2) High level signals containing high frequency components produced by a tape deck in the fast forward mode.
 - 3) Click noise produced when turning power of other components on and off.
 - 4) Click noise produced when connecting or disconnecting cords with the power on.
 - 5) Click noise produced when the cartridge is replaced with the power on.
 - 6) Click noise produced when operating amplifier switches.
 - 7) Continuous high frequency oscillation or high pitch electronically produced musical instrument sound.
 - 8) Howling when using a microphones.

SPECIFICATIONS

Type	: 3-way 3-speaker Bass-Reflex Type Twin Hyper Power-Drive Subwoofer (Magnetically-shielded type)
Speakers:	
Subwoofer	: 13.5 cm (5-3/8 in.) cone × 1
Main woofer	: 13.5 cm (5-3/8 in.) cone × 1
Tweeter	: 5.0 cm (2 in.) cone × 1
Power Handling Capacity:	
Subwoofer	: 80 W
Main Speaker	: 40 W
Impedance:	
Subwoofer	: 6 Ω
Main Speaker	: 4 Ω
Frequency Range:	
Subwoofer	: 26 Hz — 92 Hz
Main Speaker	: 92 Hz — 20 000 Hz
Sound Pressure Level:	
Subwoofer	: 75 dB/W·m
Main Speaker	: 88 dB/W·m
Dimensions (W × H × D)	: 275 mm × 317 mm × 309 mm (10-11/16 in. × 12-1/2 in. × 12-3/16 in.)
Mass	: 5.0 kg (11.0 lbs) each

Design and specifications subject to change without notice.

CONEXIÓN

- NO utilice ningún otro amplificador para operar este sistema de altavoces excepto CA-MXDVA5.
- Desactive la alimentación de todo el sistema antes de conectar los altavoces al amplificador.
- La capacidad máxima de potencia del altavoz principal del SP-MXDVA5 es de 40 W y la del altavoz de subgraves es de 80 W. En casos donde las señales descritas más abajo se apliquen a los altavoces, aunque las mismas resulten menores que la entrada máxima permisible, pueden causar una sobrecarga y quemar el cableado de los altavoces. Asegúrese de disminuir el volumen del amplificador con anterioridad.
 - 1) Ruido durante la sintonía en FM.
 - 2) Señales de alto nivel que contengan componentes de alta frecuencia producidos por un magnetófono en el modo de avance rápido.
 - 3) Ruidos de conmutación provocados al encender y apagar otros componentes.
 - 4) Ruido de conmutación al conectar o desconectar cables con los componentes encendidos.
 - 5) Ruido de conmutación cuando se reemplaza la cápsula con los componentes encendidos.
 - 6) Ruido de conmutación provocados por la operación de los selectores del amplificador.
 - 7) Continua oscilación de alta frecuencia o de sonidos de tonos altos provocados por instrumentos electrónicos.
 - 8) Aullidos al utilizar micrófonos.

ESPECIFICACIONES

Tipo	: Reflex bajo con 3-altavoces y 3 vías Twin Hyper Power-Drive Subwoofer (Tipo blindado magnéticamente)
Altavoces:	
De subgraves	: Tipo cónico de 13,5 cm × 1
Principal	: Tipo cónico de 13,5 cm × 1
De agudos	: Tipo cónico de 5,0 cm × 1
Capacidad de potencia:	
De subgraves	: 80 W
Principal	: 40 W
Impedancia:	
De subgraves	: 6 Ω
Principal	: 4 Ω
Gama de frecuencias:	
De subgraves	: 26 Hz — 92 Hz
Principal	: 92 Hz — 20 000 Hz
Nivel de presión acústica:	
De subgraves	: 75 dB/W·m
Principal	: 88 dB/W·m
Dimensiones (An × Al × Prf)	: 275 mm × 317 mm × 309 mm
Peso	: 5,0 kg cada uno

El diseño y las especificaciones están sujetos a cambio sin previo aviso.

LIGAÇÃO

- NÃO use outro amplificador para operar este sistema de altifalantes à exceção do CA-MXDVA5.
- Desligue a alimentação de todo o sistema antes de iniciar as ligações dos altifalantes ao amplificador.
- A potência efectiva máxima do altifalante principal do SP-MXDVA5 é de 40 W; a do subwoofer é de 80 W. Uma entrada excessiva resultará em ruídos anormais e possíveis avarias. Nos casos em que os sinais descritos abaixo apresentem-se nos altifalantes, mesmo que os sinais estejam abaixo do nível de entrada permissível, poderão causar uma sobrecarga e o curto-circuito dos fios dos altifalantes. Certifique-se de reduzir o volume do amplificador de antemão.
 - 1) Interferências durante a sintonia de FM.
 - 2) Sinais com níveis elevados e com componentes de alta frequência produzidos pelo deck de cassetes durante o modo do avanço rápido.
 - 3) Estalidos produzidos quando do ligar/desligar da alimentação de outros componentes.
 - 4) Estalidos produzidos ao se ligar/desligar cabos de ligação com a alimentação ligada.
 - 5) Estalidos produzidos quando da troca da célula fonocaptadora com a alimentação ligada.
 - 6) Estalidos produzidos quando do activar/desactivar dos interruptores do amplificador.
 - 7) Oscilação contínua das altas frequências ou altas tonalidades electronicamente produzidas por sons de músicas instrumentais.
 - 8) Efeito de realimentação acústica (microfonia) quando da utilização de microfone.

ESPECIFICAÇÕES

Tipo	: Reflector de graves de 3 vías e 3 altifalantes Twin Hyper Power-Drive Subwoofer (Tipo blindado magneticamente)
Altifalantes:	
Subwoofer	: Cónico de 13,5 cm × 1
Woofer principal	: Cónico de 13,5 cm × 1
Tweeter	: Cónico de 5,0 cm × 1
Potência efectiva:	
Subwoofer	: 80 W
Altifalante principal	: 40 W
Impedância:	
Subwoofer	: 6 Ω
Altifalante principal	: 4 Ω
Amplitude de frequência:	
Subwoofer	: 26 Hz — 92 Hz
Altifalante principal	: 92 Hz — 20 000 Hz
Nível da pressão sonora:	
Subwoofer	: 75 dB/W·m
Altifalante principal	: 88 dB/W·m
Dimensões (larg. × alt. × prof.)	: 275 mm × 317 mm × 309 mm
Peso	: 5,0 kg cada

Desenho e especificações sob reserva de alterações sem aviso prévio.

التوصيل

- لا تستعمل مضخم صوت آخر لتشغيل نظام السماعات هذا باستثناء للموديل CA-MXDVA5.
- أفضل الطاقة لكل النظام قبل توصيل السماعات بالمضخم.
- أقصى سعة للقدرة لتشغيل السماعة الرئيسية لنظام السماعات SP-MXDVA5 هي ٤٠ واط وللمجهر الفرعي للترددات المنخفضة هي ٨٠ واط. الدخل الزائد سيؤدي الى تشويش شاذ وامكانية حدوث تلف.
- في الحالات التي تنطبق فيها الاشارات الموصوفة أدناه على السماعات، حتى لو كانت الاشارات دون أقصى دخل مسموح به، فانها قد تسبب حملاً زائداً وحرق اسلاك السماعات. لهذا تأكد من تخفيض جهارة صوت المضخم مقدماً.
- ١) تشويش أثناء موالفة البث FM.
- ٢) اشارات ذات مستوى مرتفع تحوي مركبات تردد عال ناتجة عن جهاز كاسيت في وضع التقديم السريع.
- ٣) صوت طقطقة ينتج عند تشغيل وإيقاف الطاقة على الاجهزة الاخرى.
- ٤) صوت طقطقة ينتج عند وصل أو فصل الاسلاك بينما تكون الطاقة موصلة.
- ٥) صوت طقطقة ينتج عند استقبال الكارتريديج بينما تكون الطاقة موصلة.
- ٦) صوت طقطقة ينتج عند تشغيل مفاتيح المضخم.
- ٧) نذبذة مستمرة ذات تردد مرتفع أو نغمة عالية ناتجة إلكترونياً عن صوت آلة موسيقية.
- ٨) زعيق عند استخدام ميكروفون.

الخط

- 请勿使用其他放大器操作 CA-MXDVA5 以外的扬声器系统。
- 要将扬声器连接到放大器时，须关掉全装置系统的电源。
- SP-MXDVA5 主扬声器的最大功率储备容量为 40 W (瓦)，副低音喇叭的为 80 W (瓦)。过大的输入，将造成异常噪声，甚至损坏扬声器。当下列信号输入扬声器时，即使该信号低于最大容许输入，仍有可能造成过载而烧毁扬声器导线，故请预先调低放大器的音量控制，以籍安全。
- 1) 在 FM 调谐中产生的噪声。
- 2) 磁带录音机的快进模式中产生的含有高频成分的高电平信号。
- 3) 开关其他组成部分电源时产生的卡嗒噪声。
- 4) 接通着电源进行接线或断线时产生的卡嗒噪声。
- 5) 接通着电源更换卡盘时产生的卡嗒噪声。
- 6) 操作放大器开关时产生的卡嗒噪声。
- 7) 连续的高频率振荡或高音调电子装置产生的乐器声。
- 8) 使用麦克风时产生的嘶声。

المواصفات

规格

类型	: 3 通道 3 扬声器低音反射型 Twin Hyper Power-Drive Subwoofer (磁屏蔽型)
扬声器:	
副低音喇叭	: 锥形纸盆 13.5 cm × 1
主喇叭	: 锥形纸盆 13.5 cm × 1
高音喇叭	: 锥形纸盆 5.0 cm × 1
最大功率:	
副低音喇叭	: 80 W (瓦)
主扬声器	: 40 W (瓦)
阻抗:	
副低音喇叭	: 6 Ω (欧姆)
主扬声器	: 4 Ω (欧姆)
频率范围:	
副低音喇叭	: 26 Hz — 92 Hz
主扬声器	: 92 Hz — 20 000 Hz
声压级:	
副低音喇叭	: 75 dB/W · m
主扬声器	: 88 dB/W · m
尺寸 (W × H × D)	: 275 mm × 317 mm × 309 mm
质量	: 每个 5.0 kg

النوع	: ثلاثي التكوين ٣ سماعات من النوع العاكس Twin Hyper Power-Drive Subwoofer (نوع واقعي مغناطيسي)
السماعات:	
المجهر الفرعي للترددات المنخفضة	: نوع مخروطي ١٣.٥ سم × ١
المجهر الرئيسي للترددات المنخفضة	: نوع مخروطي ١٣.٥ سم × ١
مجهر الترددات العالية	: نوع مخروطي ٥.٠ سم × ١
سعة تشغيل القدرة:	
المجهر الفرعي للترددات المنخفضة	: ٨٠ واط
السماعة الرئيسية	: ٤٠ واط
المقاومة:	
المجهر الفرعي	: ٦ أوم
السماعة الرئيسية	: ٤ أوم
مجال الترددات:	
المجهر الفرعي	: ٢٦ — ٩٢ هرتز
السماعة الرئيسية	: ٩٢ — ٢٠٠٠٠ هرتز
مستوى ضغط الصوت:	
المجهر الفرعي	: ٧٥ ديسيبل/واط-متر
السماعة الرئيسية	: ٨٨ ديسيبل/واط-متر
الابعاد	: ٢٧٥ × ٣١٧ × ٣٠٩ مم
الوزن	: ٥.٠ كجم لكل وحدة

设计与规格如有变更，恕不另行通知。

التصميم والمواصفات عرضة للتغيير دون إشعار.

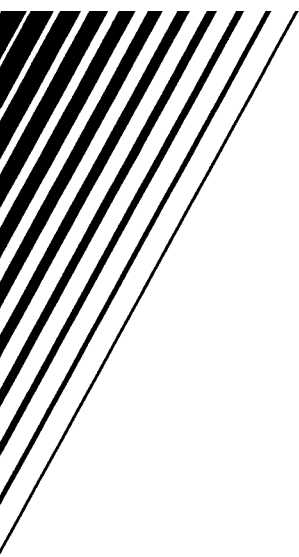

JVC
VICTOR COMPANY OF JAPAN, LIMITED